

INSTALLATION & OPERATING INSTRUCTIONS

for

IMPINGER® CONVEYOR OVENS MODEL 1300 SERIES



TO BE SERVICED ONLY BY AUTHORIZED PERSONS



WARNING AND SAFETY INFORMATION IMPORTANT

FOR YOUR SAFETY, DO NOT STORE OR USE GASOLINE OR OTHER FLAMMABLE VAPORS OR LIQUIDS IN THE VICINITY OF THIS OR ANY OTHER APPLIANCE.

DO NOT SPRAY AEROSOLS IN THE VICINITY OF THIS APPLIANCE WHILE IT IS IN OPERATION.

WARNING: IMPROPER INSTALLATION, ADJUSTMENT, ALTERATION, SERVICE OR MAINTENANCE CAN CAUSE PROPERTY DAMAGE, INJURY OR DEATH. READ THE INSTALLATION, OPERATING, AND MAINTENANCE INSTRUCTIONS THOROUGHLY BEFORE INSTALLING OR SERVICING THIS EQUIPMENT.

- Minimum clearances must be maintained from all walls and combustible materials.
- Keep the oven area free and clear of combustible material.
- Adequate clearance for air openings to the control chamber on both sides of the oven is required.
- Do not obstruct the ventilation holes in the control boxes and covers as these provide cooling air for the controls.
- The oven is to be operated only on the type of electricity as shown on the specification plate.
- This manual should be retained for future reference.
- The electrical wiring diagram is located under the control box covers.

WARRANTY

Lincoln Foodservice Products, LLC warrants to the original purchaser for use of each new Impinger® Conveyor Oven as follows: any part which proves to be defective in materials or workmanship within the warranty period will, subject to the terms of this warranty, be repaired or replaced at Lincoln's option. Repair or replacement to be done by the assigned Lincoln Authorized Service Agency. Any claims under this warranty must be presented in writing to Lincoln through the assigned Authorized Service Agency, promptly and within the warranty period.

For ovens installed in the United States and Canada, defective parts of the original equipment are warranted for one year from the date of purchase and the cost of repair or replacement labor shall be at the expense of Lincoln Foodservice Products, LLC for one year from date of purchase. (Purchase date must be within 24 months of manufacturing date for warranty to be in effect.) If the date of purchase cannot be verified, then warranty shall not exceed 18 months from date of manufacture.

For ovens installed in locations other than the United States or Canada, defective parts of the original equipment are warranted for one year from the date of purchase and the cost of repair or replacement labor shall be at the expense of Lincoln Foodservice Products, LLC for 90 days from date of purchase. (Purchase date must be within 24 months of manufacturing date for warranty to be in effect.)

This warranty shall not apply if the oven or any part is subjected to accident, casualty, alteration, misuse, abuse, faulty installation, or if the date of manufacture is altered or removed.

The obligation of Lincoln Foodservice Products, LLC is limited to the above and except as expressly stated herein. Lincoln Foodservice Products, LLC makes no guarantee or warranty, express or implied, including without limitation warranties of fitness of merchant ability with respect to Impinger® Conveyor Oven and Lincoln Foodservice products, LLC has no other liability with respect thereto including without limitation, liability for incidental, special, or consequential damages.

The following items are not covered by warranty: Any item that is defective because of utility services (power surges, high and low voltage or improper connections); conveyor belt; replacement of fuses, bulbs, gaskets, and motor brushes; adjustments and calibrations for temperatures, speed and air flows.

PURCHASER’S RESPONSIBILITY

It is the responsibility of the purchaser to:

1. See that the electric services for the oven are installed on site in accordance with the manufacturers specifications.
2. Unload, uncrate, and install the oven in its proper location in accordance with this installation operation manual.
3. See that the electric services are connected properly by a qualified installer of your choice. All such connections must be in accordance with applicable code requirements. Refer to page 6 for specific code references.

TABLE OF CONTENTS

WARRANTY AND SAFETY INFORMATION.....	2
WARRANTY.....	2
PURCHASER’S RESPONSIBILITY.....	3
UTILITY SPECIFICATION – ELECTRIC.....	3
AMBIENT TEMPERATURE REQUIREMENTS.....	3
MODEL NUMBER KEY.....	4
EXTERIOR DIMENSIONS.....	5
OVEN ACCESSORIES.....	5
CODE REFERENCES.....	6
VENTILATION GUIDELINES.....	6
GENERAL INFORMATION.....	6
UNLOADING AND UNCRATING.....	6
ASSEMBLY INSTRUCTIONS.....	7
STACKING INSTRUCTIONS.....	8
MOUNTING INSTRUCTIONS.....	9
OVEN START-UP AND SHUTDOWN.....	10
CLEANING INSTRUCTIONS.....	10
PREVENTIVE MAINTENANCE.....	11
HOW TO OBTAIN SERVICE.....	11
FUNCTIONS – THERMAL CUT-OUT SWITCH.....	11
CONVEYOR REMOVAL.....	12
CONVEYOR DISASSEMBLY FOR CLEANING.....	12
CONVEYOR REASSMBLY.....	13
FINGER REMOVAL AND DISASSEMBLY.....	14
FINGER COLUMNATING PLATE IDENTIFICATION.....	15-16
IMPINGER® CONCEPTS.....	17
APPENDIX A: LABEL DEFINITIONS.....	18-19

UTILITY SPECIFICATION

IMPINGER® CONVEYOR OVEN

Model	Input Rate	Voltage	Current	Phase	Hz	# of Wires	Agency Listing	DB Level
1300	6 kW	200 VAC	28 Amps	1	50/60 Hz	3	NSF	
1301	6 kW	208 VAC	27 Amps	1	60 Hz	3	UL, CSA, NSF	
1302	6 kW	240 VAC	24 Amps	1	60 Hz	3	UL, CSA, NSF	
1303	6 kW	220 VAC	27 Amps	1	50 Hz	3	NSF	
1304	6 kW	240 VAC	24 Amps	1	50 Hz	3	NSF	
1305	6 kW	380/220 VAC	15 Amps	1	50 Hz	4	DIN, NSF	
1306	6 kW	415/240 VAC	14 Amps	1	50 Hz	4	NSF	
1307	6 kW	200 VAC	16 Amps	3	50/60 Hz	5	NSF	
1308	6 kW	380/220 VAC	9 Amps	3	50 Hz	5	NSF	
1309	6 kW	415/240 VAC	8 Amps	3	50 Hz	5	NSF	
1310	6 kW	220 VAC	27 Amps	1	60 Hz	3		
1311	6 kW	380/220 VAC	9 Amps	3	60 Hz	5		
1312-xxx-E	6 kW	400/230 VAC	9 Amps	3	50 Hz	5	NSF, CE Certified	≤ dba 70
1313-xxx-E	6 kW	400/230 VAC	15 Amps	1	50 Hz	3	NSF, CE Certified	≤ dba 70

NOTE: Do not install this (these) oven(s) in any area with an ambient temperature in excess of 95° F / 35° C. Doing so will cause damage to unit.

MODEL NUMBER KEY

<u>COUNTRY</u>	<u>LANGUAGE</u>	<u>CODE</u>	<u>NOT USED</u>
1. France	French	B	A
2. Germany	German	C	I
3. Italy	Italian	D	O
4. Spain	Spanish	E	Q
5. United Kingdom	English	F	
6. Luxembourg	French	B	
7. Portugal	Portuguese	H	
8. Denmark	Danish	J	
9. Belgium	Dutch / French	K	
10. Netherlands	Dutch	L	
11. Ireland	English	F	
12. Greece	Greek	M	
13. Austria	German	C	
14. Finland	Finnish	N	
15. Norway	Norwegian	P	
16. Sweden	Swedish	R	

EXAMPLE: 1322-B00-EA

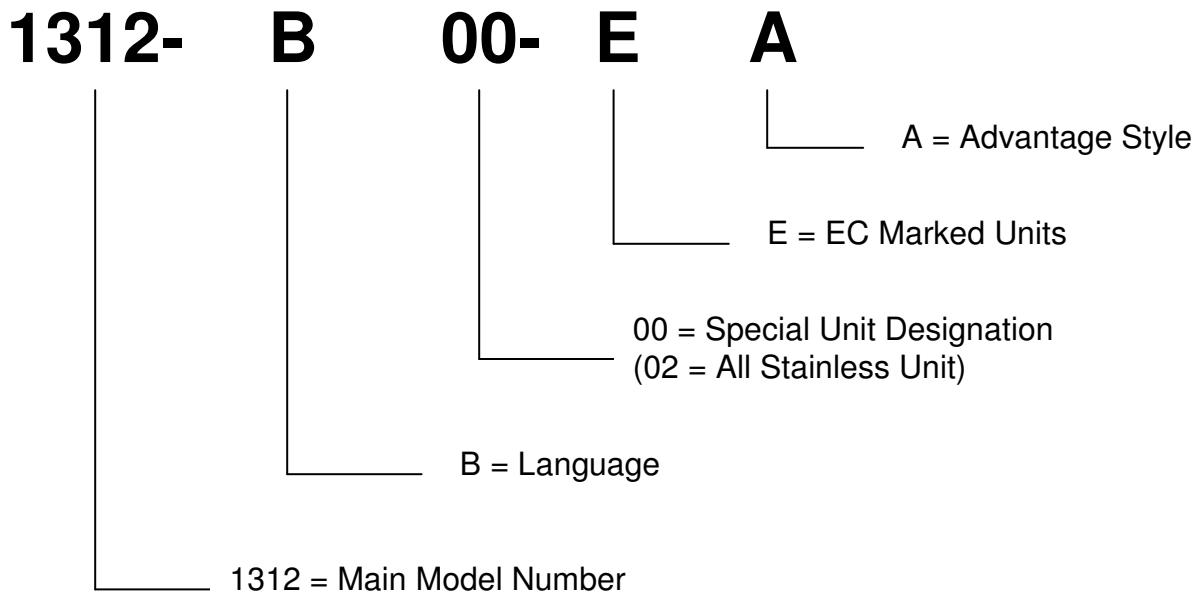

NOTE: Date of manufacture is stamped on the rating plate of each oven at the end of the serial number.

Example: XXX...01-96

EXTERIOR DIMENSIONS IMPINGER® OVEN MODELS

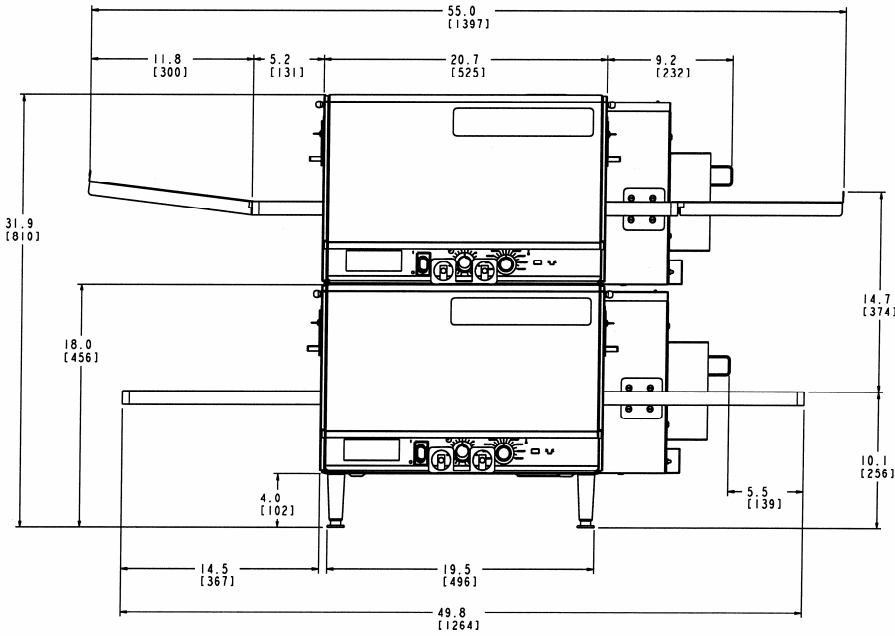

Top oven shown with conveyor #1353
 Bottom oven shown with extended conveyor #1346

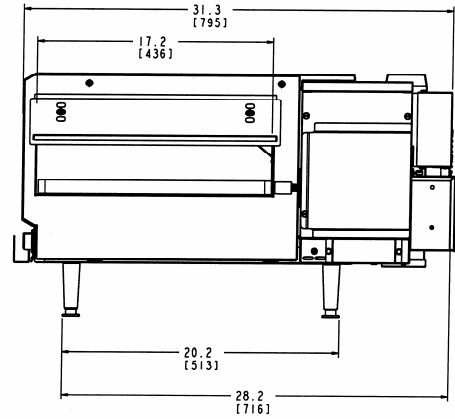

OVEN ACCESSORIES

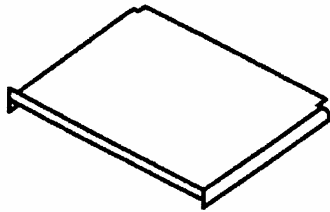

#1341 Exit Shelf – 12" Length
 #1343 Entry Incline Shelf – 12" Length

NOTE: Optional
 Columnating Plates
 listed on pages 15-16.

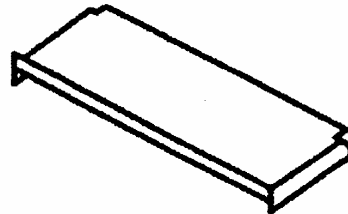

#1342 Exit Shelf – 4" Length
 #1344 Entry Incline Shelf – 4" Length



#1352 Extended Baffle, Inlet and Outlet

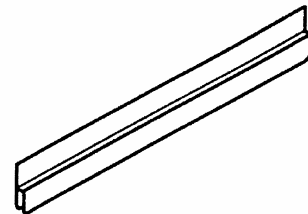

#1345 Conveyor Endstop

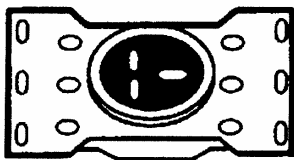

#1950 Wall Receptacle NEMA 6-50 USA & Canada
 (For Models 1301 & 1302)

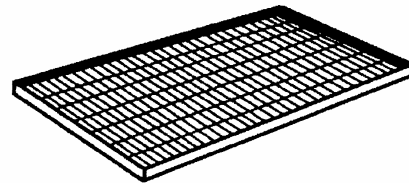

#1346 Extended Conveyor 49 3/4" Length
 #1353 Standard Conveyor 31" Length
 We recommend entry and exit shelves on standard
 length conveyor

ELECTRICAL GROUNDING INSTRUCTIONS



WARNING DOMESTIC:

As it pertains to model units 1300, 1301 and 1302 only, this appliance is equipped with a three-prong (grounding) plug for your protection against shock hazard and should be plugged directly into a properly grounded three-prong receptacle. Do not cut or remove the grounding prong from this plug.



WARNING INT'L (CE):

This appliance must be properly grounded at time of installation. Failure to ensure that this equipment is properly grounded can result in electrocution, dismemberment or fatal injury.



WARNING:

If the supply cord appears to be damaged, do not attempt to operate unit. Contact a service agent or qualified electrician to repair.

ELECTRICAL CODE REFERENCE

IN USA

When installed, this appliance must be electrically grounded and its installation must comply with the National Electric Code, ANSI-NFPA 70, latest version, the Manufacturer's Installation Instructions, and applicable municipal building codes.

IN CANADA

All electrical connections are to be made in accordance with CSA C22.1 – Canadian Electrical Code Part 1 and/or local codes.

ALL OTHER COUNTRIES

Local electrical codes will prevail.

1. Strain Relief is provided with each oven. International Dealer/Distributors provide applicable power cord/plug for each customer.
2. All pole disconnection switch 3mm open contact distance.
3. To prevent electrical shock, an equal potential bonding ground lug is provided in the back. This allows the oven to be connected to an external bonding system.
4. If used as double stack and each oven has its own disconnection switch, all switches should be close together.

SPACING

The oven must have 6 inches (152 mm) of clearance from combustible surfaces. In case other equipment is located on the right side of oven, a minimum clearance of 24 inches (609 mm) is required from that equipment.

FOR ALL OVENS: A 24-inch (609 mm) clearance at the rear of the oven must be obtainable for service access.

VENTILATION

Local codes prevail. These are the "authority having jurisdiction" as stated by the NATIONAL FIRE PROTECTION ASSOCIATION, INC. in NFPA 96, latest edition.

GENERAL INFORMATION

The instructions that follow are intended as a guide for preparing for the installation of the Impinger® Conveyor oven.

First and foremost, each crate should be examined before signing the Bill of Lading to report any visible damage caused by the trucker in transit and account for the number of crates.

IF THERE IS APPARENT DAMAGE: *United States and Canada:* Arrangements should be made to file a claim against the carrier. As Interstate Commerce Regulations require that the claim must be initiated by the consignee. *All shipments to other countries:* Freight terms will be developed and extended on an individual basis.

Proper and secure storage facilities should be arranged for the oven(s) if necessary to protect it from outdoor or damp conditions at all times before installation.

~ DO NOT LIFT EXCESSIVE WEIGHT ~

UNCRATING

When you have all the crates unloaded, open the crates and remove the plastic covers. Inspect at once for concealed damage. If anything appears to be damaged, contact the appropriate persons immediately to file a damage claim. After completing this inspection, finish unpacking the oven and all other components. Move the components inside near the area where they will be assembled in the order in which they will be assembled.

IMPINGER® ASSEMBLY INSTRUCTIONS

INSTALL LEGS AS SHOWN

 **WARNING:**
Legs MUST be installed to insure proper operation!

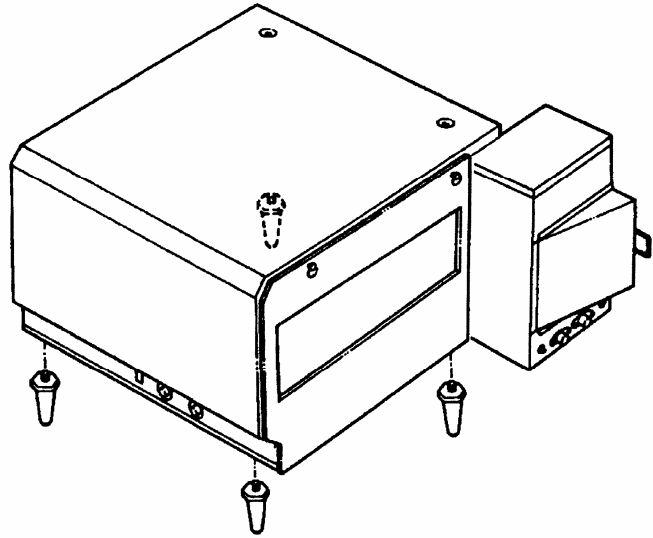

CAUTION:

Oven must be operated on approved bases only. Bottom unit must always be mounted on legs provided.



CAUTION:

Before applying power to oven, check to insure that the four (4) finger assemblies and two (2) air duct panels (upper & lower) are properly seated and have not become dislodged during shipment.

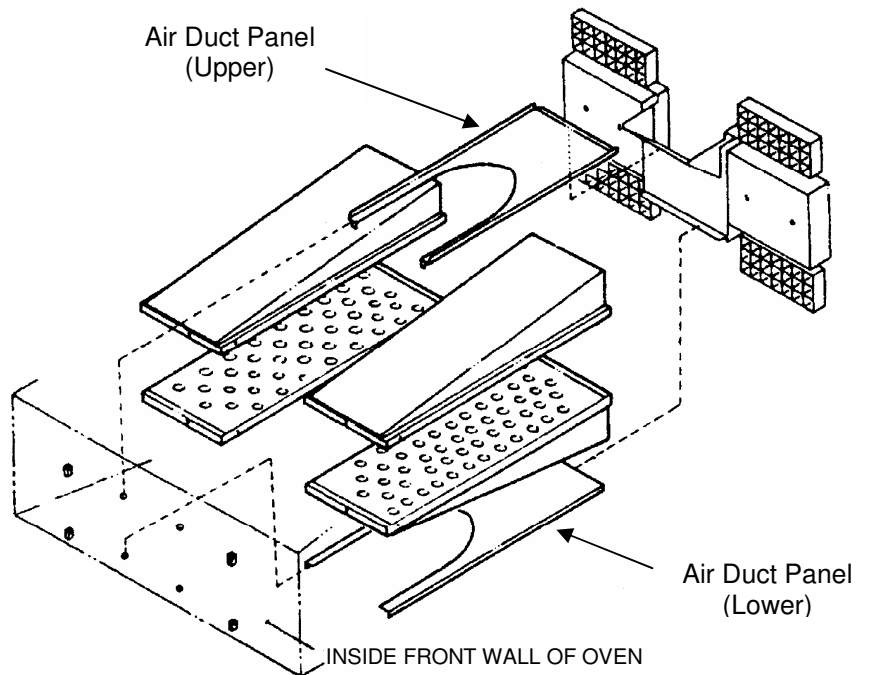
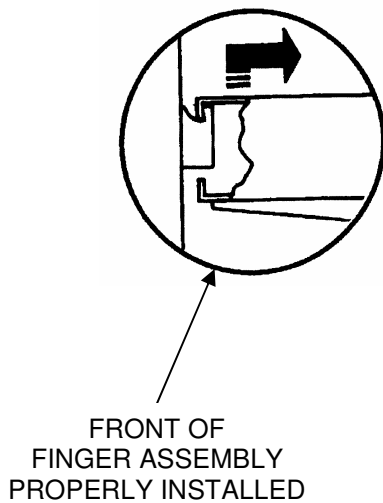

IMPINGER® STACKING INSTRUCTIONS

FOR SINGLE AND DOUBLE-STACK OVENS

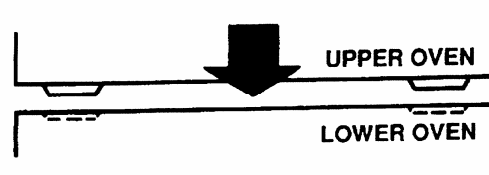

NOTE: When stacking ovens, remove bottom flue cap from top oven.

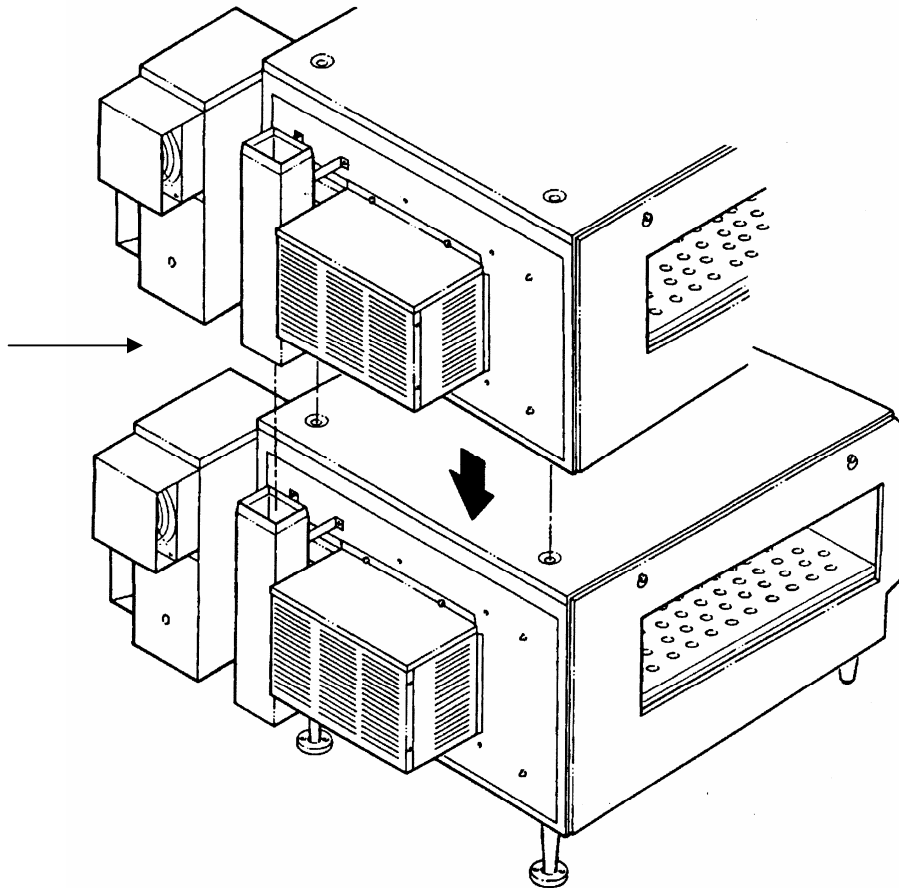

NOTE: Stack ovens so that the small “foot” on top oven fits into the “indentation” on the top of the bottom oven.



CAUTION:

If you use a double stack, please note that each oven has its own disconnect switch. Make sure that all switches are in the “OFF” position before beginning maintenance or cleaning.

COUNTERTOP MOUNTING INSTRUCTIONS

Position the oven on the countertop and carefully mark the position of the rear legs. Remove the oven from the countertop and position the mounting rings so that the large (center) hole is where the legs of the oven were marked. Mark the position of the two small holes and remove the mounting rings. Install per instruction 1 or 2 below.

1. When installing on a heavy stainless steel countertop, use the four #10-32 x 3/8" machine screws. Use a .159" diameter drill (#21) and drill through the countertop. Use a 10-32 tap through the holes. Using a screwdriver, mount the rings in position. Set the oven on the countertop so that the rear legs are in the larger holes in the mounting ring.
2. When installing on a plywood or composition board countertop, use the four #10 x 1/2" sheet metal screws. Use a .169" diameter drill (#18) and drill at least 1/2" into the countertop. Using a screwdriver, mount the rings in position. Set the oven on the countertop so that the rear legs are in the large holes in the mounting rings.

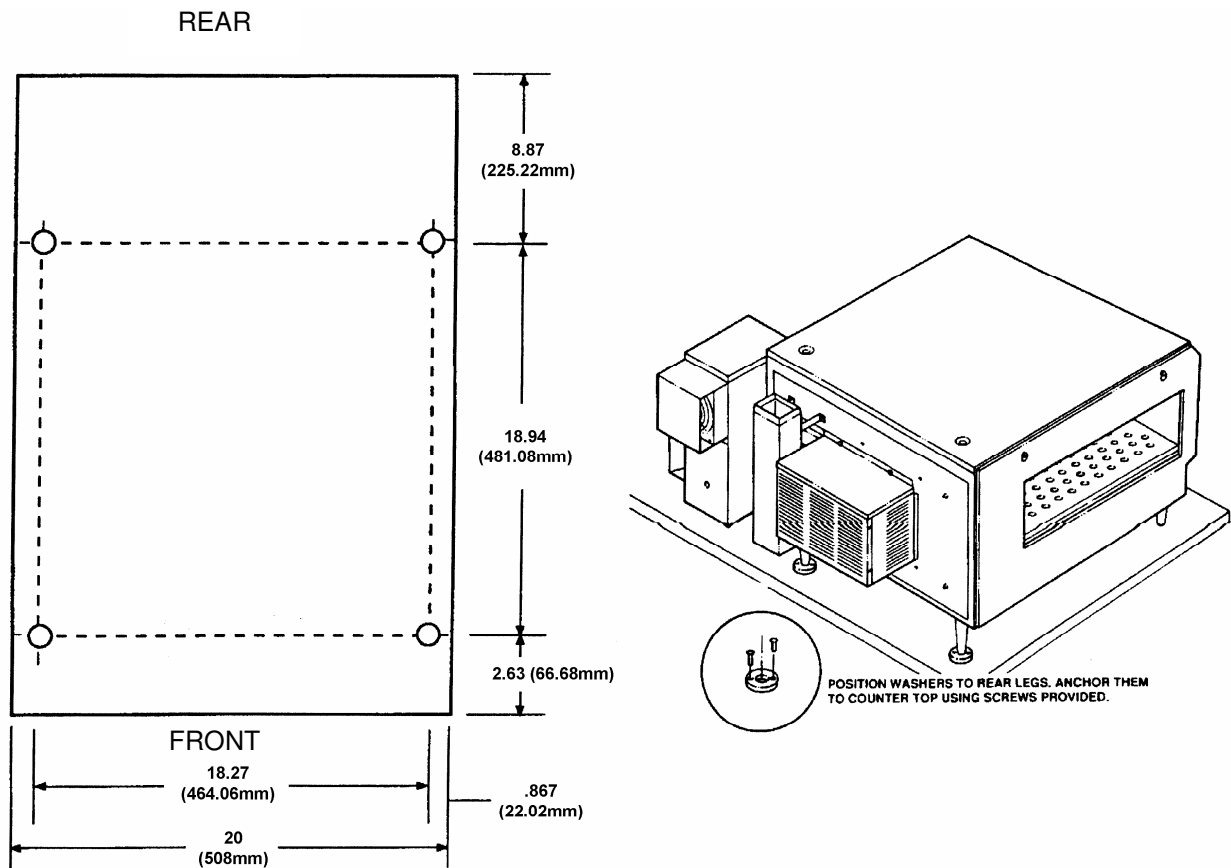

Leg location for
Impinger® Countertop Oven

START-UP

1. Push switch to "ON." The electric oven should come on immediately.
2. Turn oven dial to desired temperature.
3. Preheat oven for 30 minutes.
4. To set belt speed, adjust oven time dial to reach desired time.

SHUTDOWN

1. Push switch to "OFF."

Note: Ovens prior to serial #3018980, fan continues to operate for approximately 20 minutes. Turning on and off fan switch will reset the timer for an additional 20 minutes.

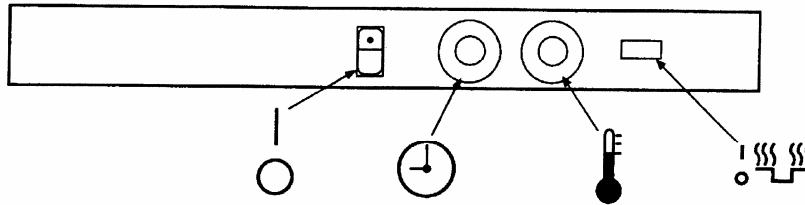

CLEANING INSTRUCTIONS

The Lincoln Impinger[®] oven contains electrical components. Before cleaning the oven, switch off and disconnect the oven from the electrical supply.

No electrical components should be subjected to moisture. It is therefore important that the oven is wiped down carefully. NEVER throw buckets of water over the oven or subject it to pressure washing from a hose or a pressure spray. If water or other liquid is spilled on the oven, make sure that none has entered the control box area before switching on. If in doubt, call your service company.



CAUTION: Oven must be cool. Do not use power-cleaning equipment, steel wool, or wire brushes on stainless steel surfaces.

DAILY:

1. Clean exterior surfaces of the oven by wiping it down with a mild detergent and clean water, or a commercial stainless steel cleaner.
2. Clean the interior by sweeping up all loose particles, then wash with a mild detergent solution and rinse with clean water.
3. Clean the conveyor belt by wiping with a cleaning cloth or brushing with a soft wire brush. Lincoln catalog #369217.

NOTE: DO NOT USE a *caustic* or *alkaline* base cleaner on interior of oven. This will ruin the aluminized finish of the oven interior. On exterior of oven, removal of deposits of baked-on splatter, oil, grease, or light discolorations may be removed with any of several commercial cleaners. Consult with your local supplier.



CAUTION: When using cleaning solutions, be sure they meet local and national health standards.

WEEKLY:

1. Remove fingers, disassemble and clean. See instructions on page 14.
2. Remove conveyor, disassemble and clean. See instructions on page 12.

OPERATOR MAINTENANCE



WARNING - DANGER:

Disconnect power supply before servicing or cleaning this oven. Safeguard power so it cannot be accidentally restored. Failure to do so could result in dismemberment, electrocution, or fatal injury.

Extensive engineering went into this oven to make it as maintenance free as possible. There is no lubrication required.

However, to achieve the maximum efficiency of the oven, it is necessary to keep it clean. For cleaning instructions see page 10. The frequency listed is only the factory's recommendations. Your use and type of products will actually determine the frequency of cleaning.

If the oven fails to operate, check the circuit breaker to be sure it is turned on. Also check the fuses on the back panel to be sure that they are good before you call the Authorized Service Agency. The name and phone number of the Authorized Service Agency should be located on the oven, or contact the factory at (260) 432-9511 for the name of the nearest Authorized Service Agency.

PREVENTIVE MAINTENANCE

Although this oven has been designed to be as trouble free as possible, periodic Preventive Maintenance is essential to maintain peak performance. It is necessary to keep the motors, fans, and electronics free of dirt, dust, and debris to insure proper cooling. Overheating is detrimental to the life of all the components mentioned.

The periodic intervals for preventive cleaning may vary greatly depending upon the environment in which the oven is operating.

You must discuss the need for Preventive Maintenance with your Authorized Service Agent to establish a proper program.

If there are any questions that the service agent cannot answer, please contact the Lincoln Technical Service department.

INFORMATION ON USE OF OVEN

As explained in "Concepts," the Impinger[®] Conveyor Oven functions by directing high velocity streams of heated air directly upon the food products. Because air is the heat source, it is effective even on sensitive foods. Compares to conventional ovens and even convection ovens, the cooking time of products in the Impinger[®] Conveyor Oven can be as much as two (2) to four (4) times faster. Several factors may affect the cooking time of any special products such as:

1. Oven Temperature Setting
2. Conveyor Speed

We encourage you to experiment with the oven by trying different temperature settings and belt speeds.

HOW TO OBTAIN SERVICE

If the oven fails to operate, check the circuit breaker to be sure it is turned on. Also check the fuses on the back panel to be sure that they are good before you call the Authorized Service Agency. The name and phone number of the Authorized Service Agency should be located on the oven, or contact the factory at (260) 432-9511 for the name of the nearest Authorized Service Agency.

FUNCTIONS

THERMAL CUT-OUT SWITCH

The CounterTop unit includes a "safety thermal cut-out switch" for your protection. This safety related device is designed to insure that the CounterTop unit will not overheat and damage the unit. In the unlikely event that the CounterTop unit would exceed the specified operating temperature range, the "safety thermal cut-out switch" will activate, thus blocking power to the CounterTop unit and causing it to turn off.



CAUTION:

In order to avoid a hazard due to inadvertent resetting of the thermal cutout, this appliance must not be supplied through an external switching device, such as a timer or connected to a circuit that is regularly switched on and off by the utility.

CONVEYOR REMOVAL

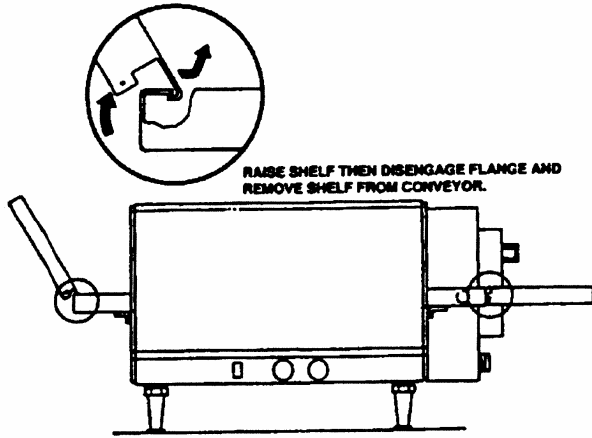

1. Remove extension shelves (if applicable).

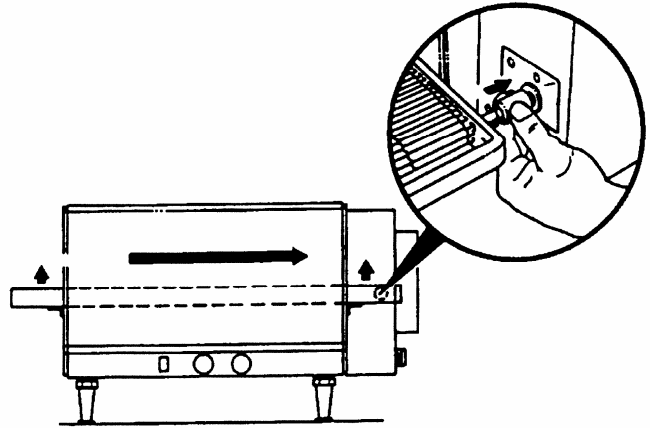

2. Push coupling away from drive lugs.
3. Remove conveyor from oven cavity.

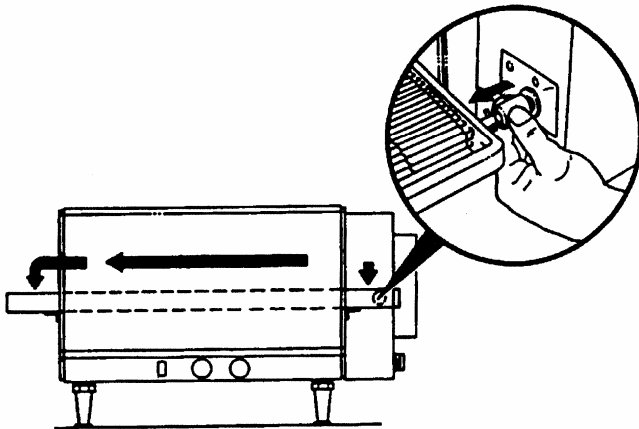

4. Reassemble in reverse order.

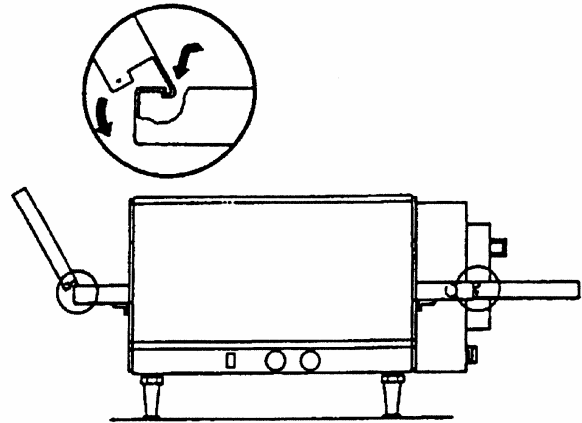

5. Install extension shelves (if applicable).

CONVEYOR DISASSEMBLY FOR CLEANING

Pull conveyor out the right end. Place on table or work surface.

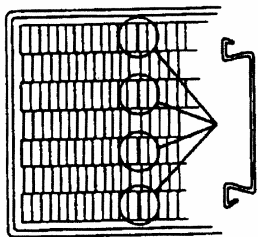

**CONNECTING
LINKS IN
FOUR PLACES**

1. Locate connecting links on the conveyor belt, turn belt to place the links on the top left end of the conveyor – approximately 8" (203 mm) from the shaft.
2. You can easily remove the connecting links by grasping them with a pair of pliers and slipping the eye of the connecting link over the wire of the other links.

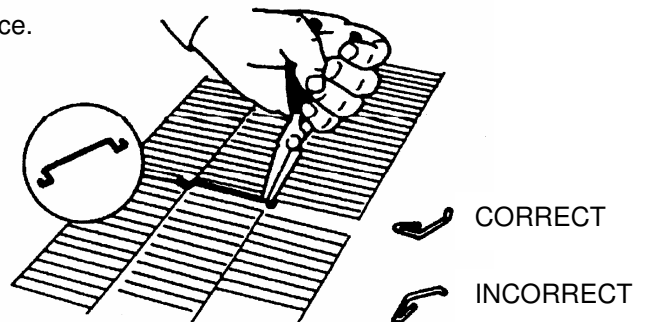

Also, notice the direction of the opening on the other links. The belt will have to be reinstalled with the opening facing the same way.

3. Carefully pull out the belt, rolling it up as you go. After you have it removed it may be placed in a pan of detergent solution to soak. Rinse with clean water.

CONVEYOR REASSEMBLY

CONVEYOR BELT INSTALLATION

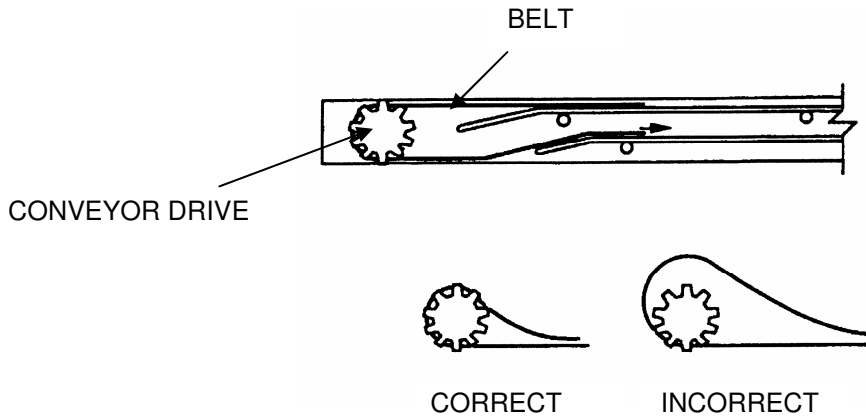

1. Put conveyor belt back on by setting the rolled belt to the left of the conveyor and thread approximately 2/3 of the belt over the bottom slider bed.
2. Put the loose end of the belt around the idler shaft and back on the conveyor. The belt must lie on top of the upper conveyor slider bed.

NOTE: The belt should curl around the conveyor sprockets and lay flat on top of the sprockets. If the belting does not curl around the sprockets and lay flat, remove the belting and turn the belting over. Reinstall.

3. Pull all of the slack belt through conveyor until both ends are on top of the conveyor on the left end.
4. Reconnect conveyor belt by slipping the connecting links back in place.

NOTE: The conveyor belt of the Impinger® Conveyor Oven does not have a tension adjustment. If the belt would become loose, a link will have to be removed to tighten. A belt that is too tight will also cause operational problems due to excessive drag. We suggest that you have a qualified service technician perform this adjustment.



WARNING:

Careful consideration should be exercised prior to removing a belt link because a belt that is too tight will impede the smooth operation of the conveyor.



CAUTION:

Do not work around conveyor belt with long hair, loose clothing, or dangling jewelry. Getting caught in the belt could result in dismemberment or fatal injury.

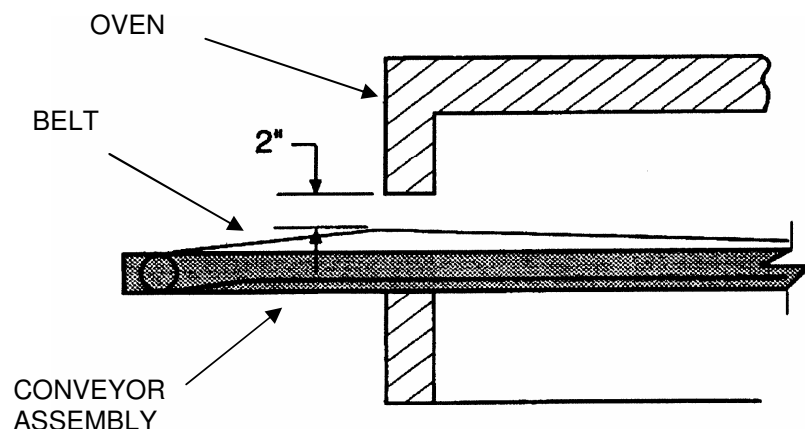

FINGERS – REMOVAL AND DISASSEMBLY FOR CLEANING



CAUTION: Oven must be cool before proceeding.

DISASSEMBLY

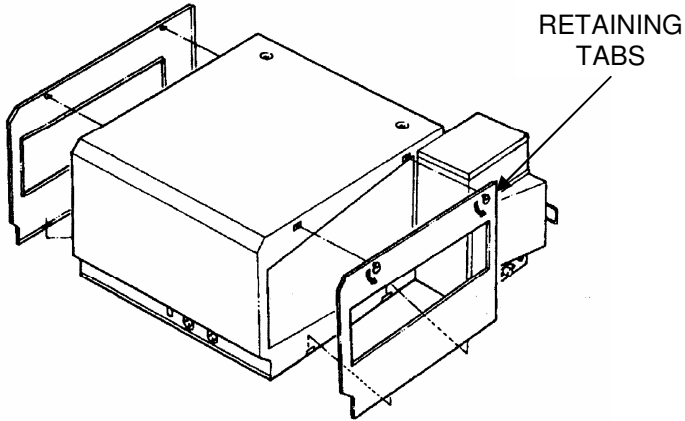

1. Release ¼-turn fasteners (2 per panel) then pull back the panel. Lift panel off lower retaining tabs.

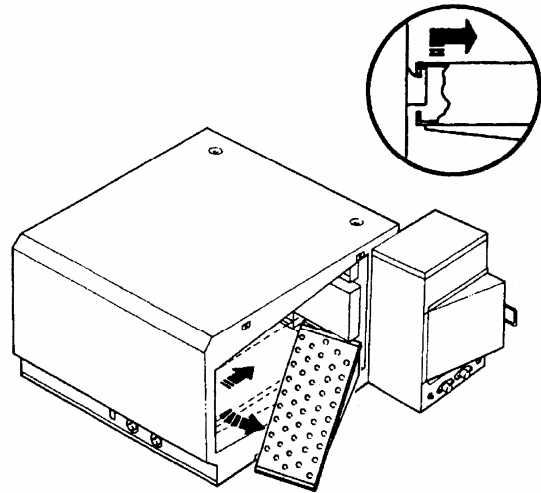

2. Lift finger assembly to clear hanger on front wall of oven. Then slide to the rear and swing out. Remove finger assembly from oven.

DISASSEMBLE FINGERS FOR CLEANING

3. Slide finger cover from housing. Lift out inner Columnating Plate.

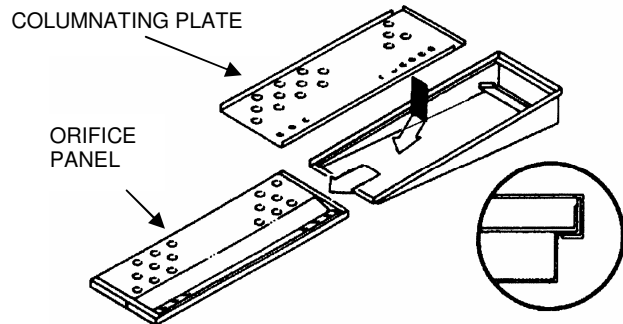

REASSEMBLY

4. Reassemble in reverse order.
NOTE: Check to insure that the holes in the columnating plate are lined up with the holes in the orifice panel.
5. Reinstall fingers in the oven. Be sure that they are fully seated over the plenum flanges and the holes are pointing toward the conveyor.
6. Reinstall cover panels (see #1).

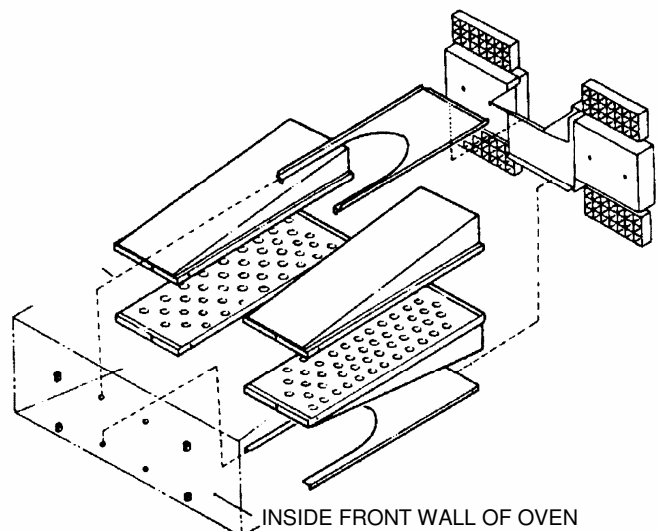

**MODEL 1301 & 1302
SERIAL #3002168
AND ABOVE**

**ALL OTHER MODELS
SERIAL #3001885
AND ABOVE**

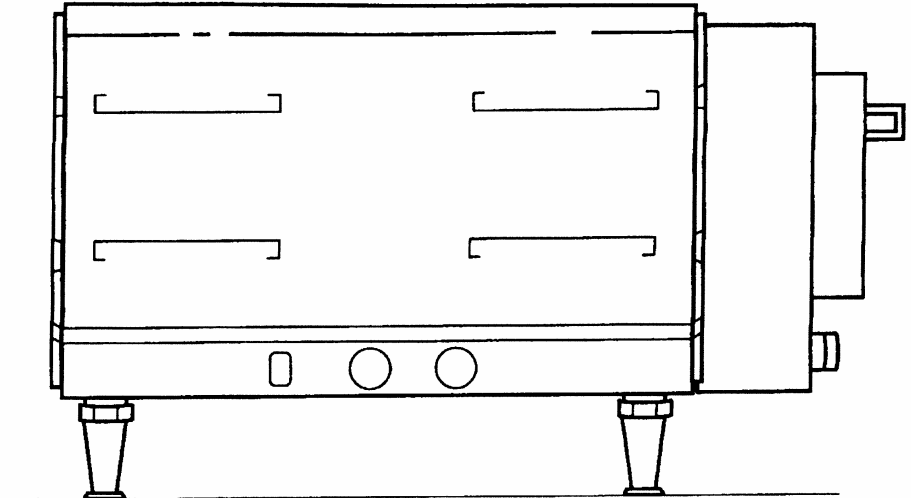

FINGER COVERS ARE MATCHED AND MAY BE INSTALLED IN ANY LOCATION

NOTE: Assembly numbers are stamped on the outer edge of the finger cover.

ASSEMBLY
NO. 1

ASSEMBLY
NO. 2

**MODEL 1301 & 1302
SERIAL #3002167
AND BELOW**

ASSEMBLY
NO. 3

ASSEMBLY
NO. 4

**ALL OTHER MODELS
SERIAL #3001884
AND BELOW**

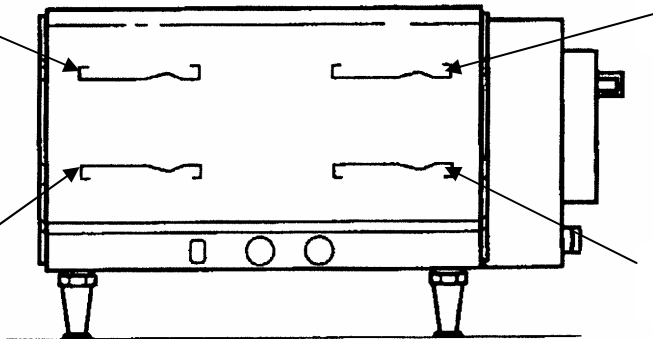

FINGER ASSEMBLIES MUST BE INSTALLED AS SHOWN

IMPINGER® FINGER COLUMNATING PLATES

COLUMNATING PANEL #1368

- APPEARANCE: Perforated metal with 6 rows of larger holes.
- EFFECT: Maximum velocity and airflow. A relative comparison can be made between a 1368/1508.
- APPLICATION: 95% of all cooking applications will use these panels in all four fingers. An Impinger® CounterTop is shipped with #1368 panels in the top and bottom finger housing.

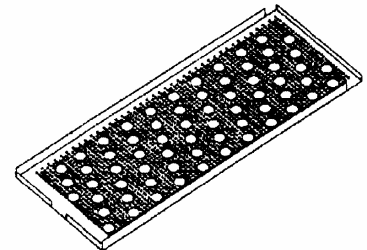

NOTE: All ICT's will be shipped with this configuration unless you specify otherwise.

IMPINGER® FINGER COLUMNATING PLATES (CONT'D)

COLUMNATING PANEL #1349

- APPEARANCE: Panel is made from solid metal with 6 rows of larger holes, then covered with perforated metal.
- EFFECT: Reduces air flow significantly. A relative comparison can be made between a 1349/1736 (Low Profile).

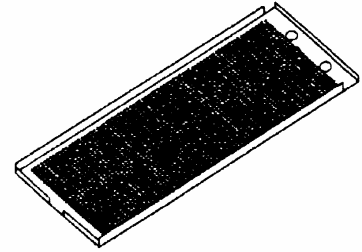

COLUMNATING PANEL #1355

- APPEARANCE: Panel is made from perforated metal. It has no large orifice columnating holes.
- EFFECT: Moderate velocity. A relative comparison can be made between a 1355/1511.

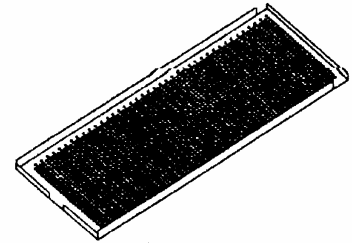

COLUMNATING PANEL #1356

- APPEARANCE: Panel is made from solid metal with only 2 rows of holes open in one side of the panel; then the open holes are covered with perforated metal.
- EFFECT: Extreme reduction in airflow, 67% less than a #1349.

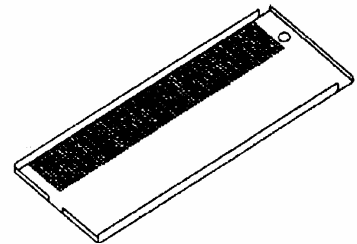

COLUMNATING PANEL #1360

- APPEARANCE: Panel is made from solid metal with 6 rows of holes.
- EFFECT: Less velocity than a #1368 or a #1355. A relative comparison can be made between a 1360/1500.

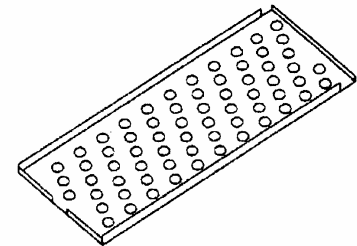

COLUMNATING PANEL #1361

- APPEARANCE: Panel made from solid blank plate, no holes.
- EFFECT: This panel would create a complete block of air from any one finger in the Impinger® CounterTop. A relative comparison can be made between the 1361/1501.

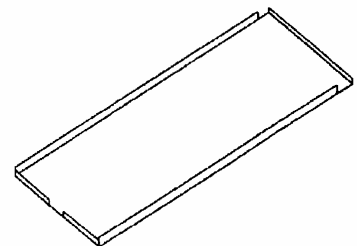

NOTE: The Impinger® CounterTop was built with the basic idea that it would be ready out of the box – uncrate, plug-in and cook! In all but 5% of your cooking applications you will do just that. You will not need to alter the ICT set-up except for very special requirements.

Our objective here is to tell you about these alternate panels because they have gone through the “new product release” process and are available to you for special applications in the field. As always, the Product Manager and the Applied Technology Department will be here should you need further information or guidance.



CAUTION:

The smaller the interior chamber, the more critical the airflow balance. A panel change in the ICT may cause front to back striping discrepancies for certain applications.

CONCEPTS

The Impinger® Conveyor Oven produced by Lincoln Foodservice Products, LLC utilizes a revolutionary cooking concept called “AIR IMPINGEMENT.” It provides exceptional baked food product quality in far less time than conventional devices on the market. The “AIR IMPINGEMENT” system directs a high velocity stream of heated air at the food product being baked. This blast effect penetrates the boundary layer of air encircling the product and heats the food more efficiently because the air concentrates heat on the product. Greater heat transfer rates, which result in products baking two to four times faster than conventional means, are possible with “AIR IMPINGEMENT.”

The “AIR IMPINGEMENT” process develops the high velocity air stream with a specially designed fan that draws super-heated air from a heat source (electric). This air is directed through a plenum chamber to patented “JET FINGERS” which have hundreds of focused jetports that “impinge” the heated air onto the product surface. The heated air is recycled to the heat source after striking the product, thus reducing energy consumption.

The “AIR IMPINGEMENT” process is tolerant enough for sensitive food products and effect proper crisping and even browning of such products as they pass through the oven – because air is the medium that heats the food product.

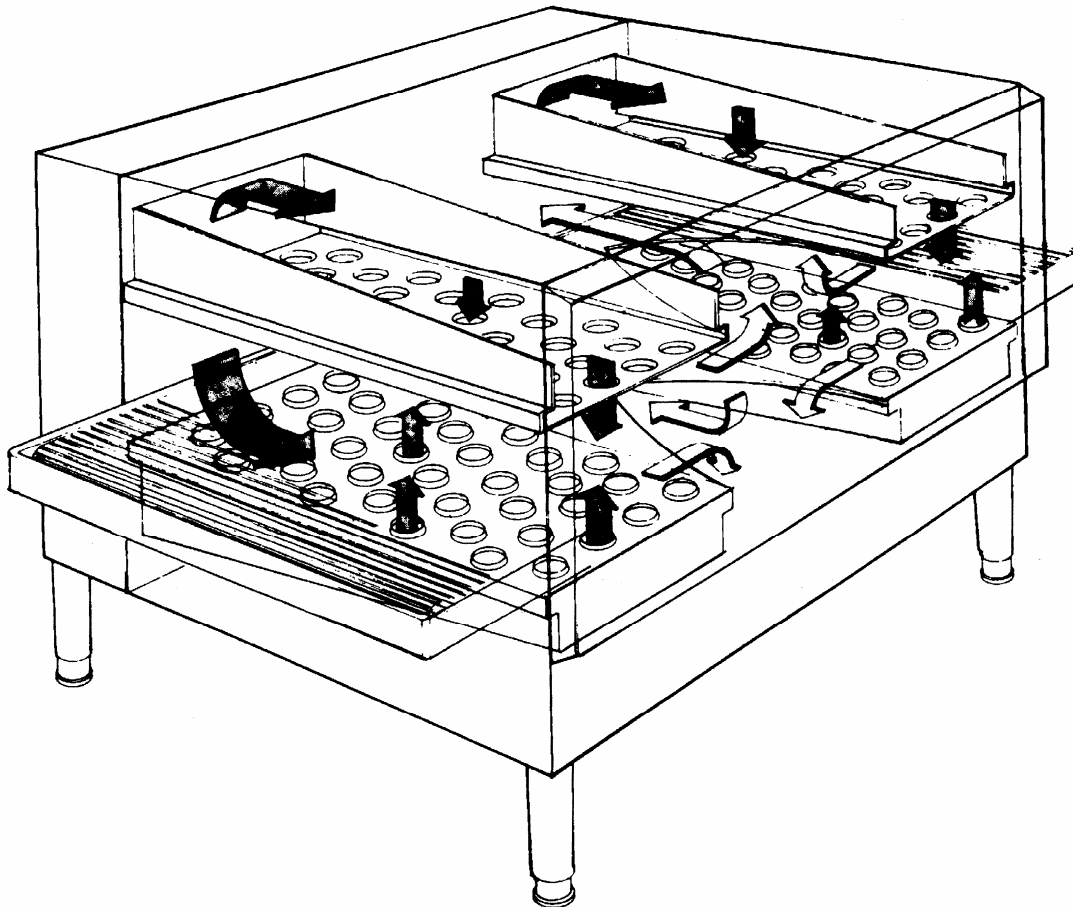

APPENDIX A – LABEL DEFINITIONS



CAUTION HOT SURFACE



CLOCK, TIME SWITCH, TIMER



TRANSFORMER



DANGEROUS VOLTAGE



EQUIPOTENTIALITY GROUND



PROTECTIVE EARTH GROUND



EARTH GROUND

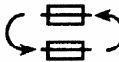

CHANGE FUSES

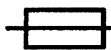

FUSE



POWER OFF



POWER ON

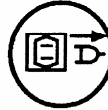

DISCONNECT POWER



TEMPERATURE, HEAT

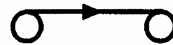

CONVEYOR



FAN

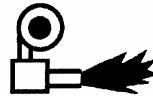

BURNER

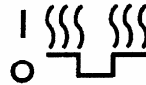

HEAT CYCLE



READY, TIMER INDICATOR



RESET



HIGH TEMPERATURE, HEAT

APPENDIX A – LABEL DEFINITIONS (CONT'D)

A AMPS

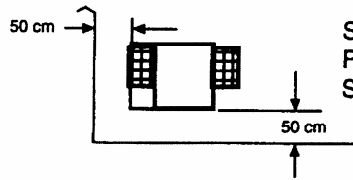

SERVICE ACCESSIBILITY,
PROVIDE MIN REAR AND
SIDE CLEARANCE

V VOLTS



ORIFICE - MAIN

kW KILOWATTS/HR

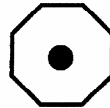

ORIFICE - LOW FIRE



TYPE OF GAS



AC

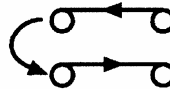

TO REVERSE BELT
CONVEYOR DIRECTION
L TO R #29 TO J3 #32 TO J2
R TO L #32 TO J3 #29 TO J2



1/2 COOK TIME

Lincoln Foodservice Products, LLC has developed a worldwide sales and service network second to none in our industry. It is headed by a sales, service and marketing management staff of more than 60 seasoned foodservice professionals. We manufacture and market Impinger Conveyor ovens, Wear-Ever and Centurion cookware, Redco food slicers, cutters and wedgers, Fresh-O-Matic food warmers that are stocked by a national network of more than 1,400 distributors nationwide. Adding to this extensive dealer base, 74 master parts distributors supply more than 400 independent service agencies throughout the world. Those agencies employ nearly 1,200 service representatives. The end result – a cohesive international network designed to serve every need of the professional foodservice operation.

With the products, experience and service network that Lincoln provides, any foodservice operation can be sure that expert assistance is always no more than a phone call away. For additional information on sales, service, warranties and parts, just call the Lincoln National Service Manager at our Fort Wayne, Indiana headquarters. We'll be happy to assist!



**Lincoln Foodservice Products, LLC
1111 North Hadley Road
Fort Wayne, Indiana 46804
United States of America**

**Telephone: (260) 459-8200
U.S. Fax: (888) 790-8193
Int'l Fax: (260) 436-0735**

Service Hotline: (800) 678-9511

www.lincolnfp.com

