

DIMENSIONS

| | A | | B | | C | | D | | E | | F | | G | |
|-------------|-------|-------|-------|-------|-----|-----|-----|------|-------|------|------|-------|-------|-------|
| | in. | cm. | in. | cm. | in. | cm. | in. | cm. | in. | cm. | in. | cm. | in. | cm. |
| Panorama® 5 | 37 | 94 | 33.75 | 85.7 | 2 | 5.1 | 12 | 30.5 | 23.63 | 60 | 46 | 116.8 | 39.5 | 100.3 |
| Panorama® 7 | 44.25 | 112.4 | 40 | 101.6 | 2 | 5.1 | 15 | 38.1 | 29 | 73.6 | 56.5 | 143.5 | 45.50 | 115.6 |

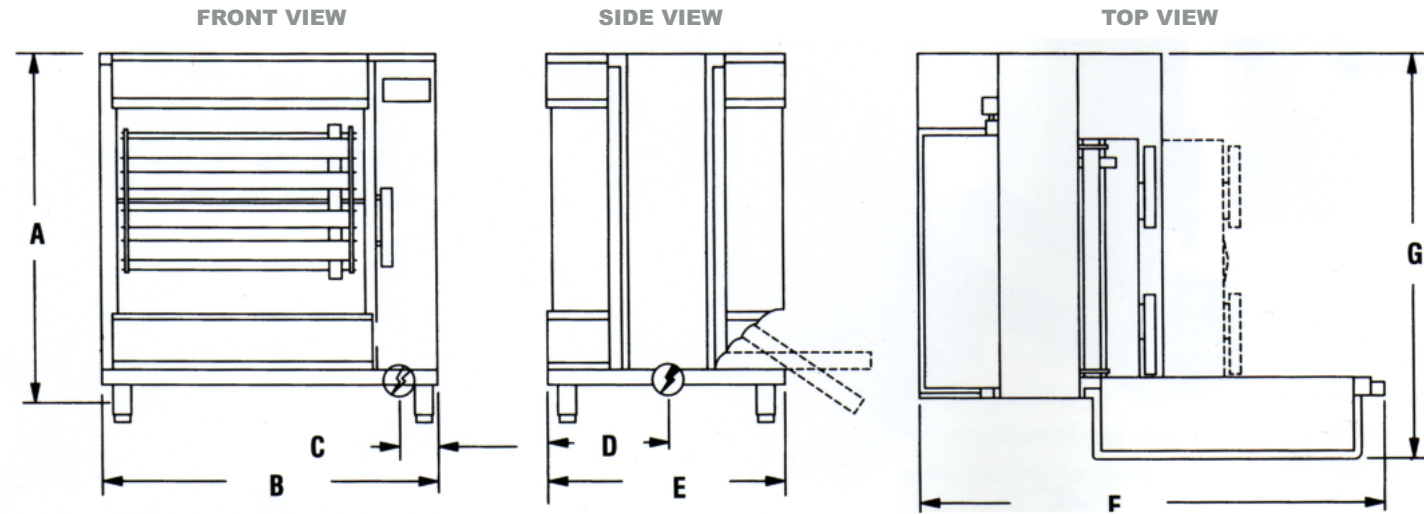

SPECIFICATIONS

| Product # | Voltage/Amps | | | | KW | Net Wgt.* (lbs/kg) | Ship Wgt.* (lbs/kg) | Ship Vol* (cu.ft/cu. m) |
|----------------------------------|--------------|---------|-----------|-----------|------|-----------------------|------------------------|----------------------------|
| | 208V IØ | 240V IØ | 208V 3Ø** | 240V 3Ø** | | | | |
| PANORAMA® 5 (Model #SP-5) | | | | | | | | |
| 15861 | 28.9 | -- | 16.7 | -- | 6.0 | 225/102.2 | 250/113.5 | 27/0.76 |
| 15686 | -- | 25.0 | -- | 14.5 | 6.0 | 225/102.2 | 250/113.5 | 27/0.76 |
| PANORAMA® 7 (Model #SP-7) | | | | | | | | |
| 19201 | -- | -- | 30.7 | -- | 11.0 | 335/152 | 390/177 | 34/1.0 |
| 19203 | -- | -- | -- | 26.6 | 11.0 | 335/152 | 390/177 | 34/1.0 |

* Measurements are approximate. ** AMP rating per leg.

ELECTRICAL CONNECTION NOTE:

The Panorama® 5 is equipped for field installation on a dedicated branch circuit, either single- or three-phase AC only. The Panorama® 7 is equipped for field installation on a dedicated branch, three-phase AC circuit only.

OPTIONS & ACCESSORIES

- Coated Roasting Pan
- Coated Combo Basket
- Locking Door Handle
- Uncoated Spit
- Cart
- Pre-programmed Control

BID SPECIFICATIONS FOR CONVECTION/ROTISSERIE OVEN

The Convection/Rotisserie Oven shall be a Merco Savory model Panorama® _____. Product Number _____, rated at _____ watts, _____ volts, _____ phase AC.

Standard equipment shall include:

- Heavy-gauge stainless steel tempered glass construction.
- Digital timer with programming function controls.
- Metal-encased (sheathed) heating elements.

MERCO SAVORY GUARANTEE

One (1) year warranty from date of purchase on both parts and labor. See price list for full details and conditions.

1111 North Hadley Road
Fort Wayne, Indiana 46804
Tel: (260) 459-8200
Fax: (260) 459-8240
Toll Free: (800) 547-2513
Web: <http://www.mercosavory.com>

 **Merco Savory**
Enodis



Printed in the USA • Design and Specifications are subject to change without notice.
© 2004 Merco Savory, Inc. • All Rights Reserved.

1454-2.5M-07/04-SP

PANORAMA®
rotisserie ovens



Dramatic in display... and sales. The Panorama® rotisserie ovens with the fast cooking and quick heating abilities of a convection oven.

 **Merco Savory**
Enodis

The Merco Savory Panorama® Rotisserie Oven, with its superior “cook and hold” qualities, is the perfect merchandiser for a variety of menu items. Panorama® enables food to be cooked with a unique combination of radiant and convection heating that seals in juices with little shrinkage and adds an appetizing golden color. This attractive oven makes a great showcase to display hot, ready-to-serve foods.



DIGITAL TIMER



PROGRAMMABLE CONTROL

Digital Timer and Programmable Controls for effortless “dial-in” time and temperature setting. Pre-programmed, one-touch menu selector with automatic time/temperature control also available.

Exclusive Curved Glass Design allow for full, panoramic view that draws attention to products as they cook.

Wide, Illuminated Enclosure always draws attention to the product inside.

Attractive, Heavy-Gauge Stainless Steel Construction is easy to clean and stays new looking.

Oven Interior And Accessories Easily Lift Out for Fast and Easy Sink or Warewasher Cleaning



2-Door Access makes loading and unloading quick and simple.

Angled Drip Pan and Pull-Out Lower Drawer with Pouring Spout neatly collects juices for disposing or making gravy.

The Merco Savory Panorama® Rotisserie Oven is Available in Two Models



Panorama® 5

Panorama® 7

Accessories

Combo Baskets are perfect for vegetables, chicken parts, fish, ribs and roasts.

Roasting Pans are ideal for baked dishes, including pasta, casseroles, and vegetables.

Stainless Steel, Wheeled Cart is made exclusively for the Panorama® Rotisserie Ovens.



Combo Baskets



Roasting Pans



Cart

Productivity Information*

| Product | Cooking Time | | Yield | |
|----------------|--------------|-------------|-------------|-------------|
| | Panorama® 5 | Panorama® 7 | Panorama® 5 | Panorama® 7 |
| Chicken, whole | 80-85 min. | 90-95 min. | 20 | 35 |
| Chicken, parts | 50-55 min. | 60-65 min. | 18 lbs. | 30 lbs. |
| Ribs, pork | 50-60 min | 65-70 min. | 10 lbs. | 16 lbs. |
| Roasts, rolled | 60-65 min. | 70-75 min. | 25 lbs. | 35 lbs. |
| Fish Filets | 10-20 min. | 15-20 min. | 20-25 | 28-35 |

*Depends on weight, size and quality of individual products.