



# PARTS & SERVICE MANUAL

## Impinger II Express Series

International Models

---

### MODELS:

Please note that the model numbering system changed March 2007. The chart below shows the old model numbering system and its matching new model number system. Please see Model Number Key section on next page for additional information.

Old Model Number	→	New Model Number
1154-000-EA	→	1154-z00-U-Kxxxx
1154-080-EA	→	1154-z00-U-Kxxxx
1154-V80-EA	→	1157-z00-U-Kxxxx
1155-000-EA	→	1155-z00-U-Kxxxx
1155-080-EA	→	1155-z00-U-Kxxxx
1155-V80-EA	→	1158-z00-U-Kxxxx
1164-000-EA	→	1164-z00-U-Kxxxx
1164-080-EA	→	1164-z00-U-Kxxxx

P/N: L371086  
REV: 10.21.09

Lincoln Foodservice Products, LLC  
1111 North Hadley Road  
Fort Wayne, Indiana 46804  
Telephone: 260.459.8200  
Fax: 260.436.0735  
Technical Support: 260.459.8200  
lincolnfp.com

## MODEL NUMBER KEY

EXAMPLE: 1154-B00-E-K1801

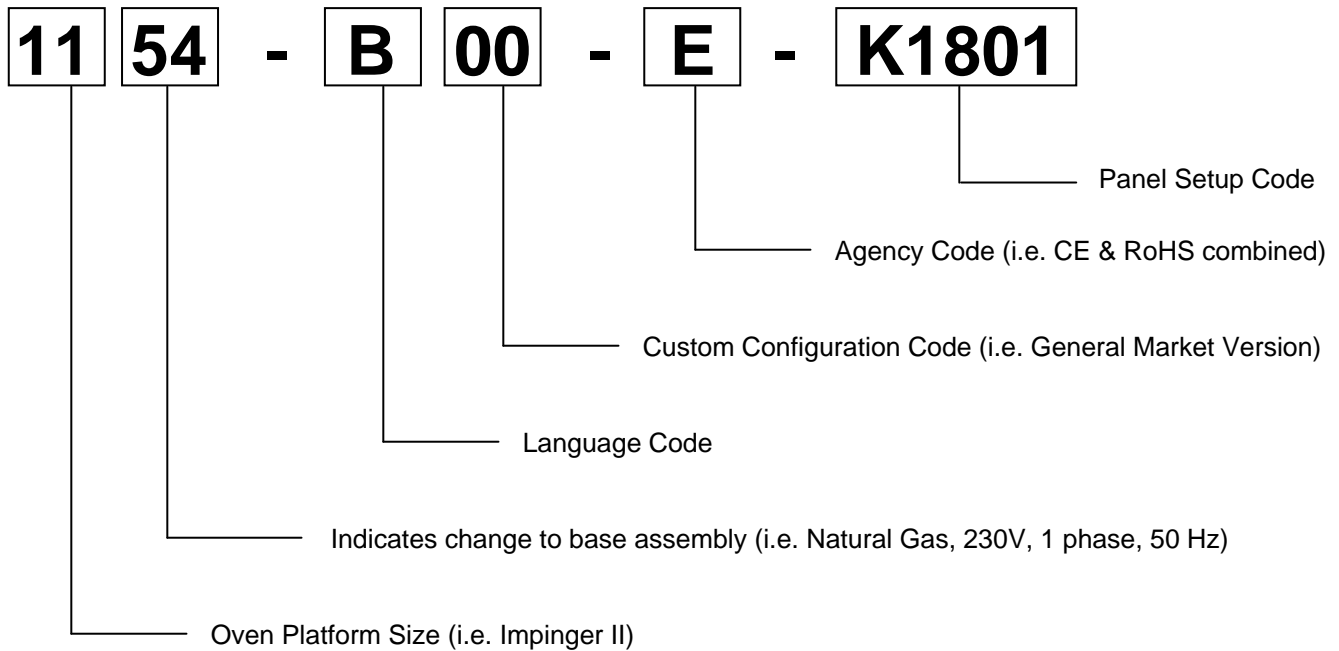

CODE	LANGUAGE	COUNTRY	CODE	LANGUAGE	COUNTRY
0	English	Dom. & Int. Default	N	Finnish	Finland
B	French	France/Luxembourg	O	Restricted	---
C	German	Germany	P	Norwegian	Norway
D	Italian	Italy	Q	English	Japan
E	Spanish	Spain	R	Swedish	Sweden
F	English	UK/India/Africa/Hungary	S	English	Australia
G	Spanish	Mexico/Latin America	T	Mandarin	China
H	Portuguese	Portugal	U	Restricted	---
I	Not Used	---	V	English	Pacific Rim/Korea
J	Danish	Denmark	W	English	Middle East
K	Dutch & French	Belgium	X	Not Used	---
L	Dutch	Netherlands	Y	Not Used	---
M	Greek	Greece	Z	Not Used	---

### AGENCY CODE TABLE

CODE	AGENCY
N	No Agency
E	CE & RoHS compliance combined
U	US & Canada compliance only
A	Advantage style oven to be phased-out
B	Australia AGA

## SEQUENCE OF OPERATIONS IMPINGER II ADVANTAGE DIGITAL EXPRESS

SERIES 1154 EXPORT	NAT. GAS	230VAC	50 HZ.	1 PHASE
SERIES 1155 EXPORT	LP GAS	230VAC	50 HZ.	1 PHASE
SERIES 1157 EXPORT	NAT. GAS	230VAC	50/60HZ	1 PHASE
SERIES 1158 EXPORT	LP GAS	230VAC	50/60HZ	1 PHASE

POWER SUPPLY	Electrical power to be supplied to the oven by a three conductor service.
CONTROL BOX AUTO COOL DOWN	When the temperature in the control box reaches 120°F ± 3°F (48.9°C ± 1.7°C), the cooling fan thermostat will switch power to the control box cooling fan. The thermostat will interrupt power to the cooling fan when the control box temperature falls to 100°F ± 3°F (37.8°C ± 1.7°C).
MAIN FAN CIRCUIT Burner does not go through filter.	Power is permanently supplied through a 10 amp oven fuse to the normally open double pole oven fan switch. Closing the oven fan switch supplies line voltage to the main fan motor. Closing the main fan switch also supplies voltage to the cooling fan through the EMI Filter to the primary of the control transformer, the conveyor motor, and the burner system.
BURNER CIRCUIT	Closing the oven fan switch supplies line voltage through the normally open air pressure switch (closed by the air pressure from the main fan), through the normally closed oven cavity hi-limit thermostat (opens at 662°F, 350°C), and to the ignition control.
IGNITION CONTROL	The ignition control switches line voltage to the combustion blower motor. The combustion air pressure switch switches from normally closed to normally open upon sensing air pressure in the burner housing. After a pre-purge period of between 30 and 60 seconds, the spark is energized, the main gas valve and the burner pilot light are energized, and ignition should now occur.
TEMPERATURE CONTROL	Closing the oven fan switch supplies line voltage to the primary of the control transformer. Secondary voltage, 24VAC, is supplied to the oven control. The oven control is set to desired temperature. The thermocouple will provide varying millivolts to the oven control. The oven control supplies line voltage to the temperature regulation valve at intermittent intervals to maintain the desired temperature. The display on the oven control will indicate when the temperature regulation valve is energized. NOTE: The display also indicates oven temperature.
CONVEYOR DRIVE	Closing the oven fan switch supplies line voltage to the conveyor motor and to the primary of the control transformer. Secondary voltage, 24VAC, is supplied to the oven control. Setting the oven control to the desired time outputs voltage, through a reversing switch, to the conveyor motor. NOTE: The conveyor system uses a hall effect sensor and magnet to prove operation of the conveyor motor. If the conveyor motor is not running, "BELT JAM" is indicated on the display.

## SEQUENCE OF OPERATIONS IMPINGER II ADVANTAGE DIGITAL EXPRESS

SERIES 1164 EXPORT

400/230VAC

50HZ.

3 PHASE

POWER SUPPLY	Electrical power to be supplied to the oven by a four conductor service. Brown conductor is hot. Black conductor is hot. Black conductor is hot. Green conductor is ground.
MAIN FAN CIRCUIT	Power is permanently supplied, through the 10 amp oven fuse, through the normally closed control box hi-limit thermostat (opens at 140°F, 60°C), to the normally open oven fan switch. Power is also supplied to the normally open cooling fan thermostat. Closing the oven fan switch supplies line voltage to the main fan motor, the cooling fans through the EMI Filter to the primary of the control transformer and to the oven control.
HEAT CIRCUIT	Closing the oven fan switch supplies line voltage, through the normally open air pressure switch (closed by air pressure from the main fan) to the oven control. Line voltage is also supplied to the primary of the control transformer. Secondary voltage, 24VAC, is supplied to the oven control. The oven control is set to desired temperature. The thermocouple will provide varying millivolts to the oven control. The oven control supplies line voltage to the coil of the contactors at intermittent intervals to maintain the desired temperature. The display on the oven control will indicate when the contactor is energized. NOTE: The display also indicates oven temperature.
CONVEYOR CONTROL	Closing the oven fan switch supplies line voltage to the conveyor motor and to the primary of the control transformer. Secondary voltage, 24VAC, is supplied to the oven control. Setting the oven control to the desired time outputs voltage, through a reversing switch, to the conveyor motor. NOTE: The conveyor system uses a hall effect sensor and magnet to prove operation of the conveyor motor. If the conveyor motor is not running, "BELT JAM" is indicated on the display.

# SCHEMATIC DIAGRAM MODEL SERIES 1154, 1155, 1157, 1158 EXPORT EXPRESS SERIES

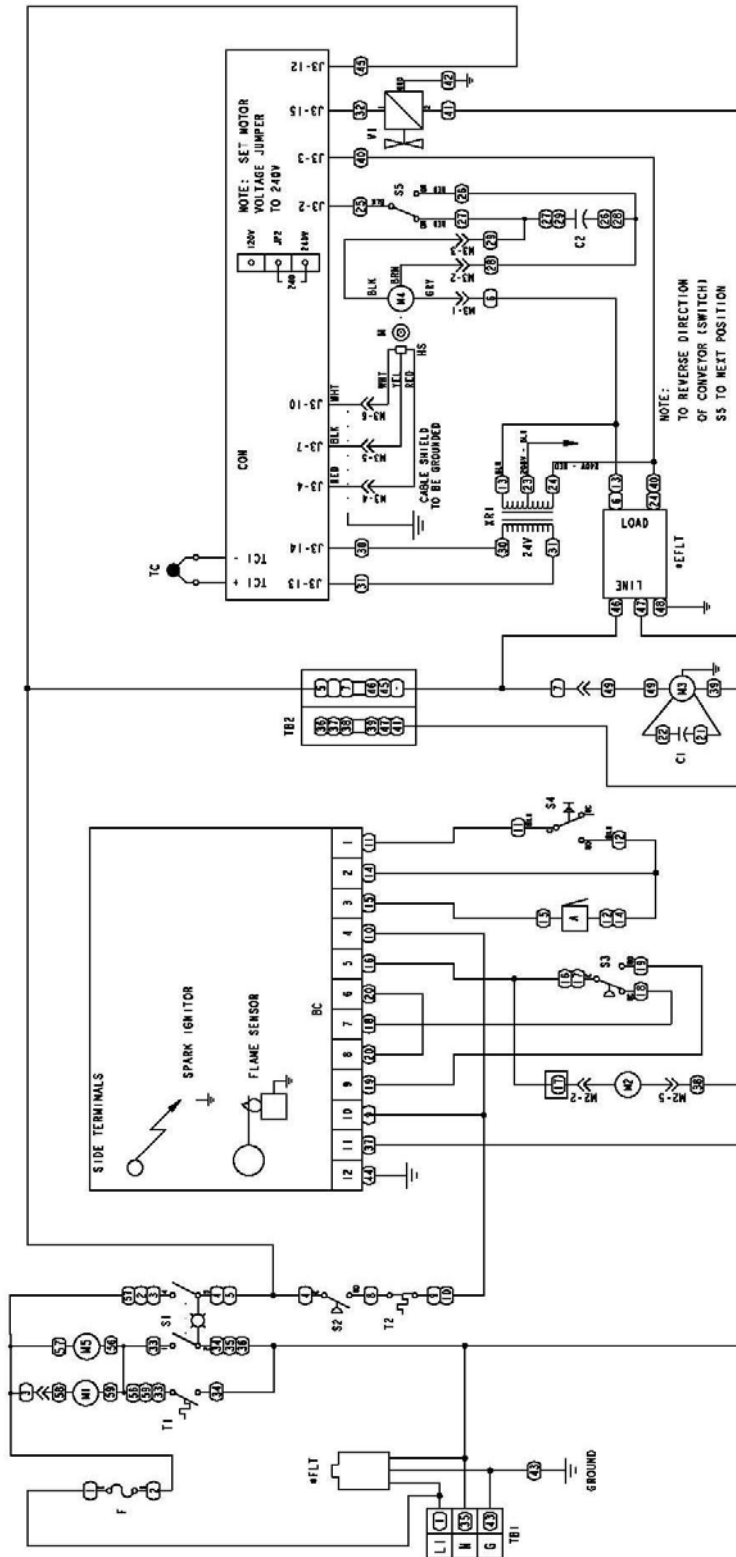

**Lincoln**  
Foodservice Products, Inc.  
FORT WAYNE, INDIANA  
IMPINGER II ADVANTAGE  
100014538

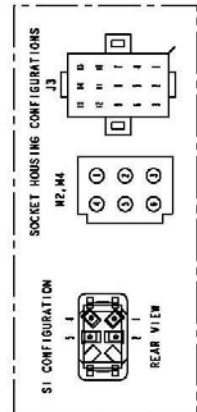

- A - ALARM
- AV - VALVE
- BC - BURNER AIR VALVE CONTROL
- C1 - CAPACITOR, MAIN FAN, 7.5 MFD
- COM - CONTROL, OVEN
- F - FUSE, OVEN, 10A
- FLT - FILTER, RTA
- HS - HALL SENSOR
- M - MOTOR, COOLING FAN
- M2 - MOTOR, BURNER BLOWER
- M3 - MOTOR, MAIN FAN
- M4 - MOTOR, CONVEYOR
- S1 - SWITCH, OVEN POWER
- S2 - SWITCH, OVEN AIR PRESSURE
- S3 - SWITCH, BURNER BLOWER AIR PRESSURE
- S4 - SWITCH, BURNER RESET
- S5 - SWITCH, CONVEYOR REVERSE
- T2 - THERMOSTAT, CONTROL BOX COOLING
- T3 - THERMOSTAT, OVEN
- TB1 - TERMINAL BLOCK, SUPPLY
- TB2 - TERMINAL BLOCK, DISTRIBUTION
- V1 - VALVE, TEMPERATURE REGULATION
- W - WIRE

# SCHEMATIC DIAGRAM MODEL SERIES 1164 EXPORT EXPRESS SERIES

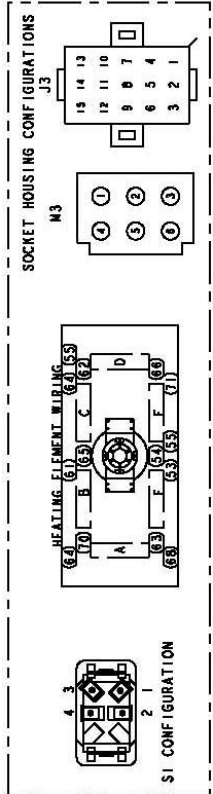
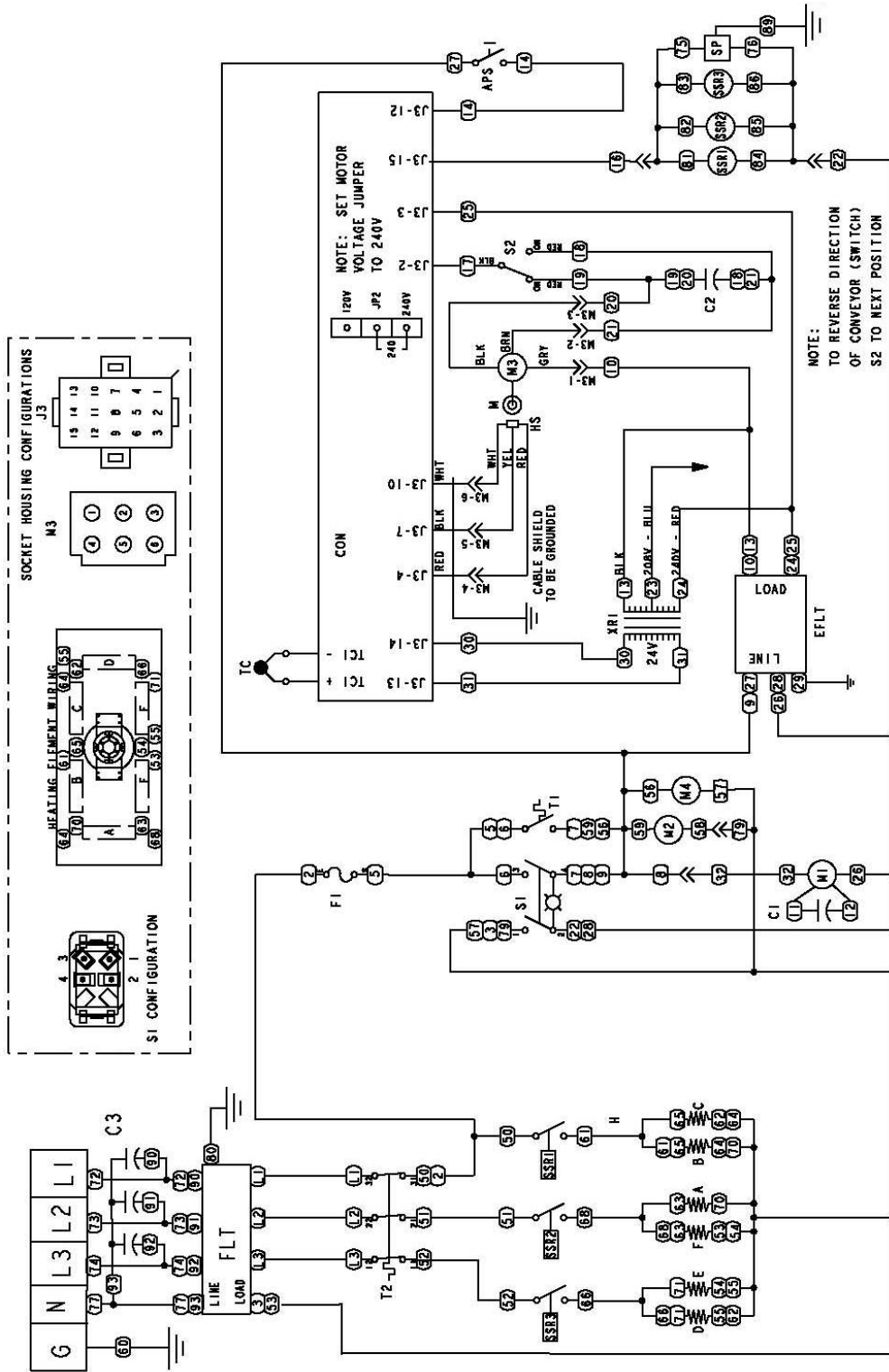

**Lincoln**  
Foodservice Products, Inc.  
FORT WAYNE, INDIANA  
Impinger Ovens

- M3 - MOTOR, CONVEYOR
  - SSR1, SSR2, SSR3 - SOLID STATE RELAY, HEATER
  - S1 - SWITCH, OVEN POWER
  - S2 - SWITCH, CONVEYOR REVERSING
  - SP - SURGE PROTECTOR
  - T1 - THERMOSTAT, COOLING FAN
  - T2 - THERMOSTAT, OVEN HI LIMIT
  - TC - THERMOCOUPLE, TYPE K
  - XRI - TRANSFORMER, CONTROL
  - (XX) - WIRE NUMBERS
- APS - AIR PRESSURE SWITCH
  - C1 - CAPACITOR, MAIN FAN
  - C2 - CAPACITOR, CONVEYOR MOTOR
  - COM - EMI FILTER CAPACITOR ASSY
  - CON - CONTROL, OVEN
  - EFLT - FILTER, EMI
  - FI - FUSE, MOTOR & CONTROLS, 10A
  - H - HEATER, MOTOR NOISE
  - HS - HALL EFFECT SENSOR
  - M1 - MOTOR, MAIN FAN
  - M2, M4 - MOTOR, COOLING FAN

NOTE:  
TO REVERSE DIRECTION  
OF CONVEYOR (SWITCH)  
S2 TO NEXT POSITION

100015748

## TROUBLESHOOTING GUIDE IMPINGER II ADVANTAGE DIGITAL EXPRESS

SERIES 1154 EXPORT	NAT. GAS	230VAC	50 HZ.	1 PHASE
SERIES 1155 EXPORT	LP GAS	230VAC	50 HZ.	1 PHASE
SERIES 1157 EXPORT	NAT. GAS	230VAC	50/60HZ	1 PHASE
SERIES 1158 EXPORT	LP GAS	230VAC	50/60HZ	1 PHASE

REFER TO PROPER SCHEMATIC FOR IDENTIFIED COMPONENTS

SYMPTOM	POSSIBLE CAUSE	EVALUATION
Oven fan will not run	Incoming power supply	Check breaker, reset if required. Check power plug to be sure it is firmly in receptacle. Measure incoming power, call power co. if needed.
	Fuse, 10 amp	Check, replace if necessary.
	Fuse holder	Check, replace if necessary.
	Switch, main fan	With power off, check continuity between switch terminals. Replace as needed.
	Motor, main fan	Check for opens, shorts or grounds. With power off, turn fan blade to check for locked rotor.
No control box cooling	Capacitor	Check for shorts or grounds. WARNING: Capacitor has a stored charge, discharge before testing.
	Incoming power supply	Check breaker, reset if required. Check power plug to be sure it is firmly in receptacle. Measure incoming power, call power co. if needed.
	Switch, main fan	With power off, check continuity between switch terminals. Replace as needed.
No automatic control box cooling	Cooling fan	Line voltage should now be at the cooling fan. If voltage is present, check motor for opens, shorts or grounds. With power off, check for locked rotor.
	Incoming power supply	Check breaker, reset if required. Check power plug to be sure it is firmly in receptacle. Measure incoming power, call power co. if needed.
	Cooling fan thermostat	Check the cooling fan thermostat (thermostat closes at 120°F and opens at 100°F). With the cooling fan thermostat pre-heated, check for continuity. If thermostat is open, replace cooling fan thermostat.
Oven will not heat	Cooling fan	Line voltage should now be at the cooling fan. If voltage is present, check motor for opens, shorts or grounds. With power off, check for locked rotor.
	Gas supply	Check for adequate gas supply and be sure that the manual gas shut off valve is open. Also check flexible gas line connection.
	Main fan	If not operating, refer to "Oven fan will not run".
	Air pressure switch	Check air switch terminals for supply voltage to terminals C and NO. If voltage is present on one side only, check for air tube blockage or misalignment. If these are okay, adjust air pressure switch or replace if necessary.
	Oven cavity hi-limit thermostat	Terminals are normally closed, opens at 350°C (660°F). If open, reset and test oven for proper operation. If thermostat will not hold for maximum oven temperature, and oven is not exceeding control setting, check for proper location of capillary bulb in its spring holder. If above checks are okay, replace hi-limit thermostat.
	Ignition control	Check for proper supply voltage to ignition control. Check for proper voltage to the burner blower motor. This can be checked at motor connecting plug terminal

		2 and Neutral. If voltage is present, proceed with next step, if not, wait 30 seconds, push reset button and try to restart. If this fails, check wires from burner blower motor to the ignition control. If the above checks okay, replace ignition control.
	Burner blower motor	Check for supply voltage to motor. WITH POWER OFF: Turn blower wheel to check for locked rotor. If supply voltage is present at motor connecting plug terminal 2 and Neutral, and motor does not run, replace burner blower motor.
	Air pressure switch (burner blower)	Check for proper supply voltage switching from "NC" to "NO" on ignition control. Check for air pressure switch adjustment, air tube blockage or misalignment. If these adjustments fail, replace air pressure switch.
	Ignition control	A pre-purge time of 30 to 60 seconds occurs after burner blower motor starts. Check for high voltage spark output from the ignition control. If there is no high voltage spark output, check reset button for ignition control. If there is still no high voltage output, replace the ignition control.
	Igniter/sensor assembly	Check this assembly for visible damage. Replace as needed. If there is no visible damage, check for voltage supply to igniter/sensor assembly. If there is voltage supplied to the igniter/sensor, but there is no spark, replace igniter/sensor assembly.
	Gas valve	Gas valve should open as the ignition control generates the high voltage spark. Place manometer on the pressure tap fitting (located in the gas piping just prior to the burner manifold) and check for gas pressure. If valve does not open, check reset button on ignition control, and all connections for tightness. If there is still no gas pressure, remove the ignition control from the gas valve. Check the coils of the gas valve for opens or shorts. Readings should be as follows, V1 – 2.9K ohms approx., V2 – 1.3K ohms approx. If these readings are not achieved, replace gas valve. If these readings are achieved, replace ignition control.
Flame will not stay on	Flame sensor	To check for flame sensor operation, connect a digital multimeter (capable of measuring DC microamps) between the flame sensor wire and the flame sensor connection on the ignition control. Sensor current is to be 0.9 microamps, minimum. If these readings are not achieved, replace igniter/sensor assembly. Also check for any type of damage to flame sensor wire and connections. NOTE: The DC microamp test must be conducted with the oven in low flame (bypass) operation.
	Power supply	Set the temperature to the lowest temperature setting. If there is sufficient microamp current, but the flame will not stay lit, check for proper polarity of the power supply.
	Ignition control	If there is sufficient microamp current, and there is proper polarity of the power supply, but the burner will not stay lit, check the reset button on the ignition control. If the above test is okay, replace the ignition control.
	NOTE: Flame should be on at this time	
Low flame is on, but no main flame	Control transformer	Check for supply voltage to the primary of control transformer. If no voltage is present, trace wiring back to oven fan switch. If voltage is present, check for



		24VAC at transformer secondary. If there is primary voltage, but no secondary voltage, replace control transformer.
	Conveyor motor	Check for supply voltage to the conveyor motor at wire #6 to neutral. If no voltage is present, trace wiring back to the oven fan switch. If voltage is present, but the motor will not run, check the motor windings for opens or shorts. If any of the above fail, replace the conveyor motor.
	Capacitor, conveyor motor	Check for shorts or grounds. Replace capacitor as needed. WARNING: Capacitor has a stored charge, discharge before testing.
	Switch, conveyor reversing	Check continuity between switch terminals. Replace switch as needed.
	Oven control	If there is voltage supplied to the motor, and the motor, capacitor and reversing switch check good, replace the oven control.
Conveyor motor runs, but there is no speed display	NOTE: Display will indicate "BELT JAM"	
	Oven control	Check for output voltage from oven control to hall effect sensor (sensor is located in the conveyor motor). Measure voltage at the motor connector, red wire and yellow wire. Voltage should be approx. 10VDC. If no voltage is present, trace wiring back to oven control. If there is no voltage output at the oven control, replace oven control.
	Conveyor motor	If there is voltage supplied to the hall effect sensor, check for a frequency output from the hall effect sensor. Measure frequency across the yellow and white wires in the motor connector. Frequency reading should be approx. 25-100 Hz. If these readings are not achieved, replace conveyor motor. If the readings are achieved, proceed.
	Oven control	If the hall effect sensor readings are correct, but there is no speed indicated on the display, replace the oven control

## TROUBLESHOOTING GUIDE IMPINGER II ADVANTAGE DIGITAL EXPRESS

SERIES 1164 EXPORT

400/230VAC

50HZ.

3 PHASE

REFER TO PROPER SCHEMATIC FOR IDENTIFIED COMPONENTS

SYMPTOM	POSSIBLE CAUSE	EVALUATION
Oven fan will not run	Incoming power supply	Check breaker, reset if required. Check power plug to be sure it is firmly in receptacle. Measure incoming power, call power co. if needed.
	Oven cavity hi-limit thermostat	Terminals are normally closed, opens at 660°F (350°C). If open, reset and test oven for proper operation. If thermostat will not hold for maximum oven temperature, and oven is not exceeding control setting, check for proper location of capillary bulb ion its spring holder. If above checks are okay, replace hi-limit thermostat.
	Fuse, 10 amp	Check, replace if necessary.
	Fuse holder	Check, replace if necessary.
	Switch, main fan	With power off, check continuity between switch terminals. Replace as needed.
	Motor, main fan	Check for opens, shorts or grounds. With power off, turn fan blade to check for locked rotor.
No control box cooling	Capacitor	Check for shorts or grounds. WARNING: Capacitor has a stored charge, discharge before testing.
	Incoming power supply	Check breaker, reset if required. Check power plug to be sure it is firmly in receptacle. Measure incoming power, call power co. if needed.
	Oven cavity hi-limit thermostat	Terminals are normally closed, opens at 660°F (350°C). If open, reset and test oven for proper operation. If thermostat will not hold for maximum oven temperature, and oven is not exceeding control setting, check for proper location of capillary bulb in its spring holder. If above checks are okay, replace hi-limit thermostat.
	Fuse, 10 amp	Check, replace if necessary.
	Fuse holder	Check, replace if necessary.
	Switch, main fan	With power off, check continuity between switch terminals. Replace as needed.
No automatic control box cooling	Cooling fan	Line voltage should now be at the cooling fan. If voltage is present, check motor for opens, shorts or grounds. With power off, check for locked rotor.
	Incoming power supply	Check breaker, reset if required. Check power plug to be sure it is firmly in receptacle. Measure incoming power, call power co. if needed.
	Oven cavity hi-limit thermostat	Terminals are normally closed, opens at 660°F (350°C). If open, reset and test oven for proper operation. If thermostat will not hold for maximum oven temperature, and oven is not exceeding control setting, check for proper location of capillary bulb ion its spring holder. If above checks are okay, replace hi-limit thermostat.
	Fuse, 10 amp	Check, replace if necessary.
	Fuse holder	Check, replace if necessary.
	Cooling fan thermostat	Check the cooling fan thermostat (thermostat closes at 120°F and opens at 100°F). With the cooling fan thermostat pre-heated, check for continuity. If thermostat is open, replace cooling fan thermostat.
Cooling fan	Cooling fan	Line voltage should now be at the cooling fan. If voltage is present, check motor for opens, shorts or grounds. With power off, check for locked rotor.

Oven will not heat	Main fan	If not operating, refer to "Oven fan will not run".
	Control transformer	Check for supply voltage to the primary of control transformer. If no voltage is present, trace wiring back to oven fan switch. If voltage is present, check for 24VAC at transformer secondary. If there is primary voltage, but no secondary voltage, replace control transformer.
	Air pressure switch	Check air switch terminals for supply voltage to terminals "NO" and "COM". If voltage is present on one side only, check for air tube blockage or misalignment. If these are okay, adjust air pressure switch or replace if necessary.
	Oven control	Check for 24VAC supply to oven control. If no voltage is present, trace wiring back to control transformer. Check for supply voltage to oven control. If no voltage is present, trace wiring back to oven fan switch. If voltage is present, check for a read-out on the display. If there is no read-out on the oven display, replace oven display. If there is a read-out on the oven control, set the control to maximum temperature (see Installation operation manual for temperature adjustment). With the control at maximum temperature, check for supply voltage to the mercury contactor. If there is voltage at the contactors, proceed to "Mercury contactor" for next check. If there is no voltage at the mercury contactor, trace wiring back to the oven control. If there is no voltage output at the oven control, check the read-out on the oven control. If the oven control reads "PROBE FAIL" this indicates that the thermocouple has failed or become disconnected from the oven control.
	Thermocouple	Check to see that the thermocouple is securely connected to the oven control. If the thermocouple is connected to the oven control, and the display indicates "PROBE FAIL", disconnect the thermocouple from the oven control and measure the resistance of the thermocouple. The thermocouple should read approx. 11Ω. If these readings are not achieved, replace the thermocouple. If these readings are correct, proceed.
	Oven control	If the thermocouple checks good, but the oven control indicates that there is a thermocouple failure, replace the oven control. If the oven control indicates a temperature reading but the oven will not heat, proceed.
	Thermocouple	WITH POWER ON AND THERMOCOUPLE ATTACHED TO THE OVEN CONTROL: Measure the DC millivolt output of the thermocouple. Refer to the thermocouple chart (located in the "Removal" section of the manual) for proper millivolt readings. If these readings are not achieved, replace thermocouple.
	Oven control	If the thermocouple checks good, but there is no supply voltage output to the contactor, replace the oven control. If there is supply voltage output to the contactor, proceed.
	S.S. Relays	Check for supply voltage to the contactor coil. If voltage is present and the contactor will not activate, replace the contactor Also check each contactor for high voltage input and output.
	Heating element(s)	Check the Amp draw on each power leg for proper load. Check the specification plate for rating information. If the Amp draw is high or low, check the

		individual elements for opens, shorts and proper resistance. WITH POWER OFF; To check resistance of the elements, remove all leads from the elements and use a digital multimeter. The element resistance should be as follows: 230V – 33 ohm. Replace heating elements as needed.
Oven heats with switch off	Contactator	The contactator has probably failed in the closed position. If there is no voltage at the operating coil, but there is high voltage output from the contactator, replace the contactator.
Intermittent heating	Thermal/overload of main fan motor	The main fan motor is equipped with internal thermal protection and will cease to operate if overheating occurs. As the motor overheats and cools, this will cause the heating system to cycle on and off intermittently. Improper ventilation or lack of preventive maintenance may cause this problem. Also, most of the problem listed under "Oven will not heat" can cause intermittent failure.
Conveyor will not run Display reads "belt jam"	Incoming power supply	Check breaker, reset if required. Check power plug to be sure it is firmly in receptacle. Measure incoming power, call power co. if needed.
	Fuse, 10 amp	Check, replace if necessary.
	Fuse holder	Check, replace if necessary.
	Switch, main fan	With power off, check continuity between switch terminals. Replace as needed.
	Control transformer	Check for supply voltage to the primary of control transformer. If no voltage is present, trace wiring back to oven fan switch. If voltage is present, check for 24VAC at transformer secondary. If there is primary voltage, but no secondary voltage, replace control transformer.
	Conveyor motor	Check for supply voltage to the conveyor motor at wire #10 to neutral. If no voltage is present, trace wiring back to the oven fan switch. If voltage is present, but the motor will not run, check the motor windings for opens or shorts. If any of the above fail, replace the conveyor motor.
	Capacitor, conveyor motor	Check for shorts or grounds. Replace capacitor as needed. WARNING: Capacitor has a stored charge, discharge before testing.
	Switch, conveyor reversing	Check continuity between switch terminals. Replace switch as needed.
	Oven control	If there is voltage supplied to the motor, and the motor, capacitor and reversing switch check good, replace the oven control.
Conveyor motor runs, but there is no speed control	Oven control	Check for output voltage from oven control to hall effect sensor (sensor is located in the conveyor motor). Measure voltage at the motor connector, red wire and yellow wire. Voltage should be approx. 10VDC. If no voltage is present, trace wiring back to oven control. If there is no voltage output at the oven control, replace oven control.
	Conveyor motor	If there is voltage supplied to the hall effect sensor, check for a frequency output from the hall effect sensor. Measure frequency across the yellow and white wires in the motor connector. Frequency reading should be approx. 25-100 Hz. If these readings are not achieved,

		replace conveyor motor. If the readings are achieved, proceed.
	Oven control	If the hall effect sensor readings are correct, but there is no speed indicated on the display, replace the oven control

## REMOVAL, INSTALLATION AND ADJUSTMENTS

### IMPINGER II ADVANTAGE DIGITAL EXPRESS SERIES

#### CAUTION

BEFORE REMOVING OR INSTALLING ANY COMPONENT IN THE IMPINGER OVEN BE SURE TO DISCONNECT ELECTRICAL POWER AND GAS SUPPLY.

#### MAIN FAN – REPLACEMENT

- Shut off power at main breaker.
  - Remove motor cover from back of oven.
  - Disconnect wiring and mark for reassembly.
  - Remove bolts and slide back straight out of the oven.
  - Loosen the bolt from fan hub and remove fan from motor shaft.
- NOTE: Measure distance from fan blade to rear wall assembly before removal to aid in reassembly.
- Reassemble in reverse order and check system operation.

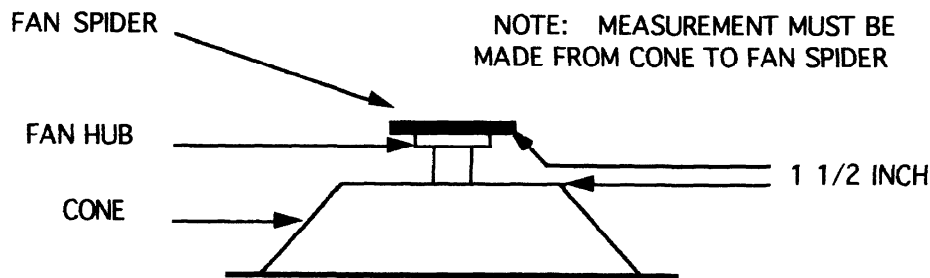

#### MOTOR, MAIN FAN – REPLACEMENT

- Shut off power at main breaker.
  - Remove motor cover from back of oven.
  - Disconnect wiring and mark for reassembly.
  - Remove bolts and slide back straight out of the oven.
  - Loosen the bolt from fan hub and remove fan from motor shaft.
- NOTE: Measure distance from the fan blade to rear wall assembly before removal to aid in reassembly.
- Remove four screws from motor support assembly.
  - Remove motor mount clamp and remove motor from oven back.
  - Remove motor mount from motor.
  - Reassemble in reverse order and check system operation.

#### CAPACITOR – REPLACEMENT

- Shut off power at main breaker.
- Remove control box cover and front panel.
- Discharge capacitor.
- Remove capacitor.
- Reassemble in reverse order and check system operation.

#### ON/OFF SWITCH – REPLACEMENT

- Shut off power at main breaker.
  - Remove control box cover and front panel.
  - Depress spring clips on sides of switch and push out.
  - Remove wires from switch and mark for reassembly.
  - Reassemble in reverse order and check system operation.
- NOTE: Make sure switch housing is fully seated in control box housing.

#### FUSE HOLDER – REPLACEMENT

- A. Shut off power at main breaker.
- B. Remove control box cover and front panel.
- C. Remove wires from fuse holder and mark for reassembly.
- D. Remove mounting screws or mounting nut on fuse holder and remove fuse holder.
- E. Reassemble in reverse order and check system operation.

#### COOLING FAN, CONTROL BOX – REPLACEMENT

- A. Shut off power at main breaker.
- B. Remove control panel top and front cover.
- C. Remove four mounting screws from fan frame.
- D. Disconnect power cord and remove fan.
- E. Reassemble in reverse order and check system operation.

#### THERMOSTAT, COOLING FAN, REPLACEMENT

- A. Shut off power at main breaker.
- B. Remove control panel top and front cover.
- C. Remove wires and mark for reassembly.
- D. Remove two mounting screws and remove thermostat.
- E. Reassemble in reverse order and check system operation.

NOTE: Push reset button on new thermostat.

#### BURNER BLOWER MOTOR – REPLACEMENT

- A. Shut off power at main breaker.
- B. Remove control panel top and front cover.
- C. Unplug motor connector.
- D. Remove three mounting screws from blower tube at burner housing.
- E. Remove air shutter assembly from old motor for assembly on new motor.
- F. Reassemble in reverse order and check system operation.

NOTE: Check air shutter at approximately ½ open and adjust to get a blue flame with an occasional tip of yellow under high flame. A view port in the burner assembly should be used to observe flame.

#### HI-LIMIT THERMOSTAT, OVEN CAVITY – REPLACEMENT

- A. Shut off power at main breaker.
- B. Remove conveyor and bottom finger assembly.
- C. Remove capillary bulb from bracket in oven chamber and pull capillary tube through tube into control box.
- D. Remove all wires and mark for reassembly.
- E. Remove mounting nut and remove thermostat.
- F. Reassemble in reverse order and check system operation. Be sure capillary tube is securely in the mount.

NOTE: Push reset button on new thermostat.

## TRANSFORMER, CONTROL – REPLACEMENT

- A. Shut off power at main breaker.
- B. Remove control panel top and front cover.
- C. Remove all wires from transformer and mark for reassembly.
- D. Remove two mounting screws from transformer base and remove transformer.
- E. Reassemble in reverse order and check system operation.

## OVEN CONTROL – REPLACEMENT (2 pcs.)

- A. Shut off power at main breaker.
- B. Remove control box cover and front panel.
- C. Remove all wiring connections and mark for reassembly.
- D. Remove oven control by pulling control from the mounting pins. Remove control from oven.
- E. Before installing new oven control, set voltage jumper (located at the bottom center of the oven control) to the proper voltage (120V/240V) position. Install the four pushbutton extensions (included with the oven control) by pushing the extensions onto the four set buttons on control.
- F. Reassemble in reverse order and check system operation.
- G. Set the oven control for the proper operating mode. The 1100 series ovens use a single temperature control system. The oven control must be set to the proper operating mode. Set the control as follows: With the oven power switch “off”, depress the “time” and “up” buttons and turn the oven “on”. Control will indicate “Imp I or Imp II”. Release the buttons, The control will indicate “Temp to store”. Press the “up” or “down” until “Imp II” appears on the display. Press the “temp” button. The control is now set for single burner operation.

## THERMOCOUPLE – REPLACEMENT

- A. Shut off power at main breaker.
- B. Remove conveyor and bottom finger assembly.
- C. Remove control panel top and front cover.
- D. Remove thermocouple from bracket in oven chamber and pull thermocouple through tube into control box.
- E. Remove two thermocouple wires from temperature control. Note wire color and location for reassembly
- F. Reassemble in reverse order and check system operation

## THERMOCOUPLE MEASUREMENT

TEMPERATURE (°F)	TEMPERATURE (°C)	D.C. MILLIVOLTS
200°	93°	2.8
250°	121°	4.0
300°	149°	5.1
350°	177°	6.0
400°	204°	7.1
450°	232°	8.2
500°	260°	9.3
550°	288°	10.4
600°	316°	11.5

## BURNER CONTROL – REPLACEMENT (S/N2045408 and Above)

- A. Shut off power at main breaker.
- B. Remove control panel top and front cover.
- C. Remove wires from control and mark for reassembly.
- D. Remove one mounting screw and remove burner control from the gas valve.
- E. Reassemble in reverse order and check system operation.



#### GAS VALVE – REPLACEMENT (S/N 2045408 and Above)

- A. Shut off power at main breaker.
- B. Shut off gas supply to the oven and disconnect the flexible gas line to the oven.
- C. Remove control panel top and front cover.
- D. Remove the manual gas shut off valve.
- E. Remove screws from the bulkhead plate on inlet gas pipe and remove inlet gas pipe.
- F. Remove wiring from ignition control (mounted on gas valve) mark all wiring for reassembly.
- G. Remove pilot tube, Disconnect pipe union in gas line and remove gas valve and piping assembly.
- H. Remove piping from gas valve.
- I. Reassemble in reverse order and check system operation.
- J. Check all gas line fittings for leaks.
- K. Adjust the gas manifold pressure on the gas valve. Refer to the specification plate on the oven for proper rating.

#### TEMPERATURE REGULATION VALVE – REPLACEMENT

- A. Shut off power at main breaker.
- B. Shut off gas supply to the oven and disconnect the flexible gas line to oven.
- C. Remove control panel top and front cover.
- D. Remove bypass tube from burner manifold.
- E. Remove wiring from valve and mark for reassembly.
- F. Remove four mounting nuts from burner manifold and disconnect pipe union.
- G. Remove temperature regulation valve and piping from oven.

#### IGNITER/SENSOR ASSEMBLY – REPLACEMENT

- A. Shut off power at main breaker.
- B. Shut off gas supply to oven.
- C. Remove control panel top and front cover.
- D. Remove gas valve assembly.(see “GAS VALVE”)
- E. Remove temperature regulation valve. (see “TEMPERATURE REGULATION VALVE”)
- F. Disconnect all wires from burner and mark for reassembly.
- G. Remove screws from burner tube and remove burner venturi.
- H. Remove two mounting screws and remove igniter/sensor assembly from burner venturi.
- I. Reassemble in reverse order and check system operation. Check all gas line fittings for leaks.

#### BYPASS ORIFICE – REPLACEMENT

- A. Shut off power at main breaker.
- B. Shut off gas supply to the oven and disconnect the flexible gas line to oven.
- C. Remove control panel top and front cover.
- D. Disconnect bypass tube from gas valve.
- E. Remove bypass orifice from gas valve.
- F. Reassemble in reverse order and check system operation.
- G. Check all gas line fittings for leaks.

#### MAIN BURNER ORIFICE – REPLACEMENT

- A. Shut off power at main breaker.
- B. Shut off gas supply to the oven and disconnect the flexible gas line to oven.
- C. Remove control panel top and front cover.
- D. Remove burner manifold. See “TEMPERATURE REGULATION VALVE”.
- E. Remove main burner orifice from burner manifold.
- F. Reassemble in reverse order and check system operation.
- G. Check all gas line fittings for leaks.

## REVERSING SWITCH – REPLACEMENT

- A. Shut off power at main breaker.
- B. Remove control panel top and front cover.
- C. Remove wires from reversing switch and mark for reassembly.
- D. Remove mounting nut and remove switch.
- E. Reassemble in reverse order and check system operation.

## CONVEYOR DRIVE MOTOR – REPLACEMENT

- A. Shut off power at main breaker.
- B. Remove control panel top and front cover.
- C. Disconnect all wiring from motor and mark for reassembly.
- D. Remove coupling from motor drive shaft.
- E. Remove four screws and remove conveyor motor and mounting bracket.
- F. Remove mounting bracket from conveyor motor.
- G. Reassemble in reverse order and check system operation.

## REVERSING CONVEYOR DIRECTION

- A. Shut off power at oven switch.
- B. Set conveyor reversing switch in the other position.
- C. Turn oven “on” and check for proper operation.

## CAPACITOR, CONVEYOR DRIVE MOTOR – REPLACEMENT

- A. Shut off power at main breaker.
- B. Remove control panel top and front cover.
- C. Discharge capacitor before removing wires. Mark wires for reassembly.
- D. Remove mounting screw and remove capacitor.
- E. Reassemble in reverse order and check system operation.

## AIR PRESSURE SWITCH – REPLACEMENT

- A. Shut off power at main breaker.
- B. Remove control panel top and front cover.
- C. Disconnect wiring from air pressure switch and mark for reassembly.
- D. Disconnect air tube from air pressure switch.
- E. Remove two mounting screws and remove air pressure switch.
- F. Reassemble in reverse order and check system operation. Be sure to calibrate new air pressure switch. For proper calibration, see below.
- G. Turn adjusting screw on air pressure switch fully counter clockwise.
- H. Turn oven “on”.
- I. Turn adjusting screw on air pressure switch clockwise until heat shuts off.
- J. Turn adjusting screw on air pressure switch counter clockwise ¼ turn.
- K. Reassemble control panel top and front cover.

## BEARING, CONVEYOR – REPLACEMENT

- A. Remove conveyor from oven and place on a flat work surface.
- B. Remove connecting links from conveyor belt. See Installation Operations manual for proper procedure. Remove conveyor belt from conveyor.
- C. Move drive shaft or idler shaft toward end of conveyor, and shaft with bearing will now slip out of conveyor frame.
- D. Remove bearing from conveyor shaft.
- E. Reassemble in reverse order and check system operation.

#### S.S. RELAYS – REPLACEMENT

- A. Shut off power at main breaker.
- B. Remove control panel top and front cover.
- C. Disconnect all wires and mark for reassembly.
- D. Remove screws from mounting bracket and remove contactor.
- E. Reassemble in reverse order and check system operation.

#### HEATING ELEMENT – REPLACEMENT

- A. Shut off power at main breaker.
- B. Remove back cover.
- C. Disconnect heating element wires and mark for reassembly.
- D. Disconnect motor wiring and mark for reassembly.
- E. Remove oven back from oven.
- F. Remove fan shroud.
- G. Heating element may now be unbolted and removed.
- H. Check new heating element for proper voltage. Reassemble in reverse order and check for proper operation.

**IMPINGER II ADVANTAGE DIGITAL EXPRESS  
GENERAL VIEW**

<b>LETTER</b>	<b>PART NUMBER</b>	<b>DESCRIPTION</b>
A*	370412	Cross support
B*	370416	Stand side
C*	369231	Caster, 4" w/threaded stem
D*	369232	Adjustable leg
E	369390	Caster, 4" w/mounting plate
F		Oven door, See "Conveyor / Door" Section
G	370010	Bottom finger housing
H	369502	Bottom finger cover
I	369504	Top finger housing (model ending with -080-A)
	370487	Top finger housing (model ending with -080-A1)
J	369503	Top finger cover (model ending with -080-A)
	370486	Top finger cover (model ending with -080-A1)
K	370415	Oven top
L	370679	Conveyor hole cover
M	371066	Baffle
N	369211	Thumb screw
O		Columnating plate, see Installation & Operations manual
P		Columnating plate, see Installation & Operations manual

*\* A new stand was designed and implemented on March 16, 2009. Parts are not compatible between old and new stand styles. See Addendum A in the back of this manual for a parts breakdown and assembly instructions.*

# GENERAL VIEW

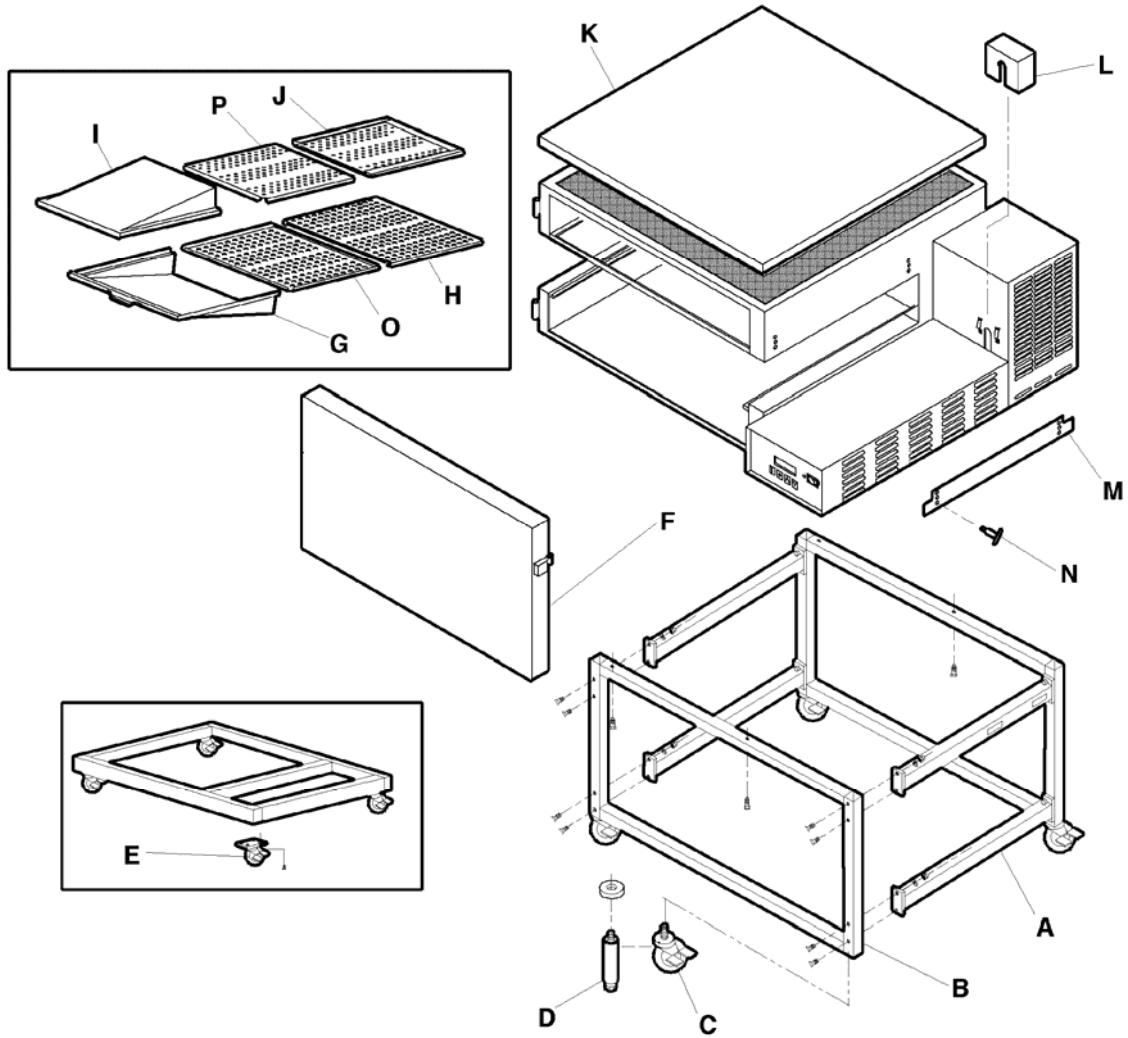

**IMPINGER II ADVANTAGE DIGITAL EXPRESS  
CONTROL BOX  
1154, 1155, 1157, 1158 SERIES**

<b>LETTER</b>	<b>PART NUMBER</b>	<b>DESCRIPTION</b>
A	357067	Hi Limit Switch
B	369771	Switch Assembly
C	390129	J-Box Cover
D	370117	Terminal Block, 5 Pole
E	370178	Junction Box
F	9003551	10 Amp Fuse Adapter Assembly
G	4071234	Beaded Ferrule
H	369192	Capacitor
I	369378	Fan Motor
J	369507	Thermostat
K	370241	Transformer
L	369125	Terminal Block, 2 Pole
M	9004238	RFI Filter Assembly
N	370682	Capacitor 450V
O	370387	EMI Filter
P	9005479	See 1154 Conveyor Motor Assembly Section
Q	370417	Main Control Board
R	9004480	Stand Off Plate Assy. (S/N 0903210000317 & Below)**
	369856	Stand Off Support (S/N 0903210000318 & Above)**
Not Shown	340034	Finger Guard
Not Shown	369579	Alarm
Not Shown	370364	Ground Lug
Not Shown	369432	On/Off Switch
Not Shown	370408	Control Facia
Not Shown	370417	Control Board
Not Shown	370409	Digital Display
Not Shown	370673	Air Pressure Switch

*\*\* This pertains to all units non-TU units.*

IMPINGER II ADVANTAGE DIGITAL EXPRESS  
CONTROL BOX  
1154 SERIES, 1155 SERIES

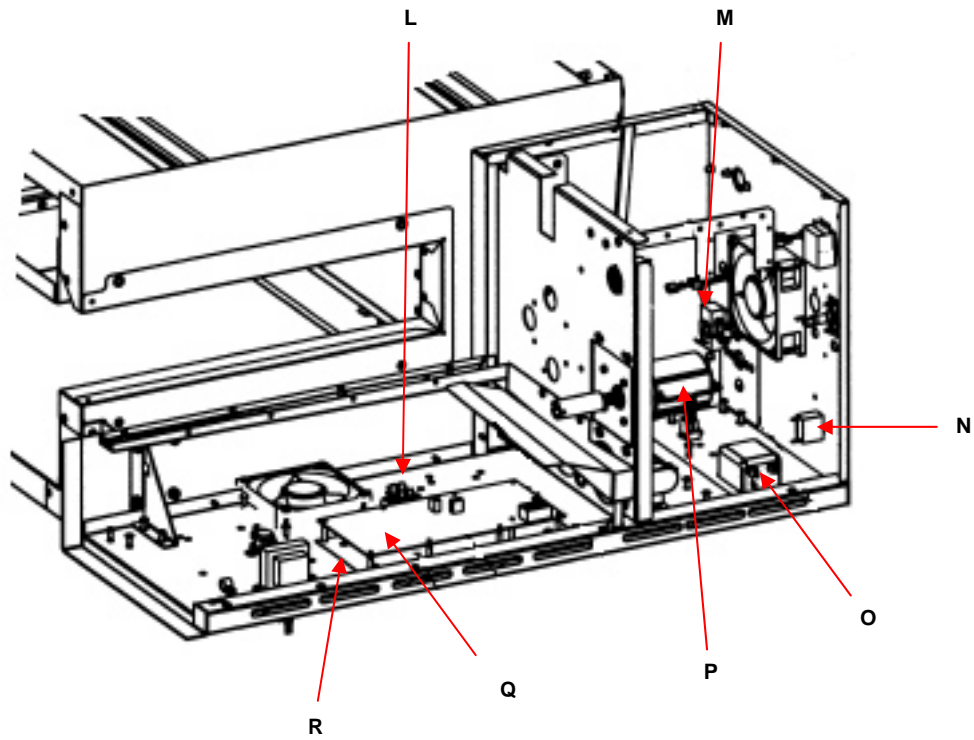
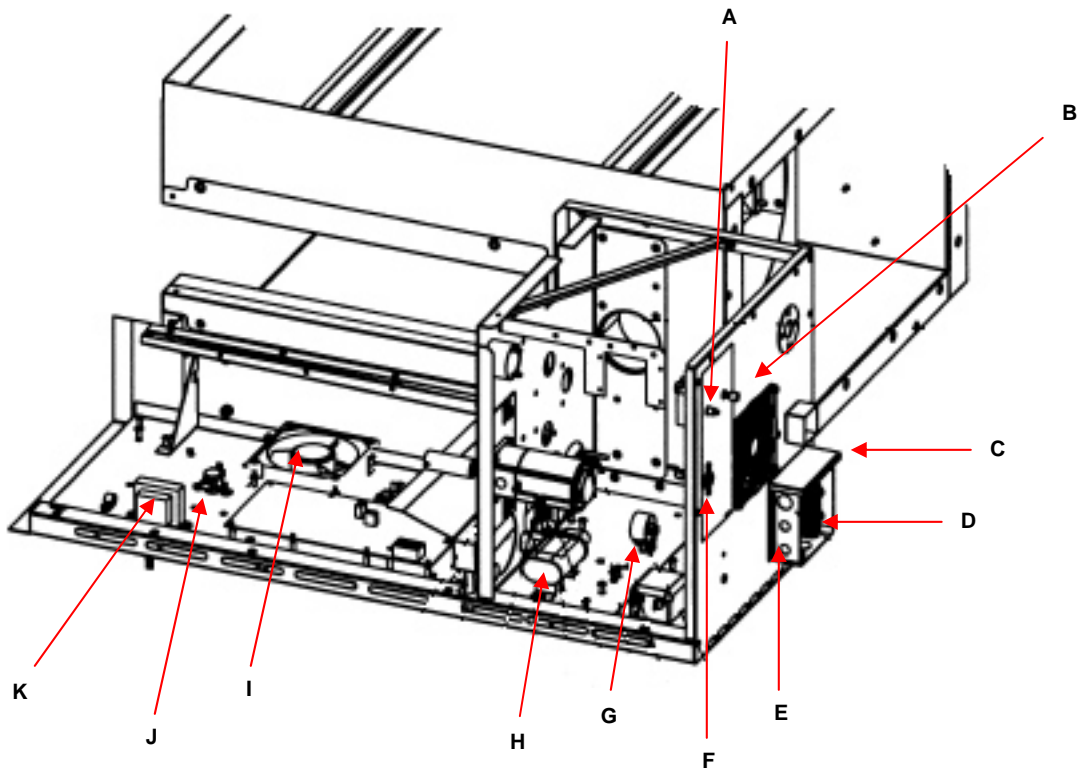

IMPINGER II ADVANTAGE DIGITAL EXPRESS  
 BURNER ASSEMBLY, NAT. GAS  
 1154 SERIES, 1157 SERIES

LETTER	PART NUMBER	DESCRIPTION
A	369556	Nat. Bypass Orifice .061/1.55mm
B	370401	Ignitor Module, Plug-In
C	370400	Valve, VK4115 A 1000
D	369582	Burner Assembly, Nat. Gas Export
E	370186	Valve, 85294101
F	369401	Air Shutter Assembly
G	369589	Burner Blower Motor
H	370397	Ignitor, Sensor Assembly
I	369654	Venturi, Nat. Gas
J	369901	Manifold, Burner
K	369689	Plug, Pressure Test
L	370036	Main Orifice, Nat.
M	370186	Solenoid Valve
N	369556	Bypass Orifice, Nat.

IMPINGER II ADVANTAGE DIGITAL EXPRESS  
 BURNER ASSEMBLY, LP GAS  
 1155 SERIES, 1158 SERIES

LETTER	PART NUMBER	DESCRIPTION
A	369557	LP Bypass Orifice .0374/0.95mm
B	370401	Ignitor Module, Plug-In
C	370400	Valve, VK4115 A 1000
D	4071136	Burner Assembly, LP Export
E	370186	Valve, 85294101
F	369401	Air Shutter Assembly
G	369589	Burner Blower Motor
H	370397	Ignitor, Sensor Assembly
I	369939	Venturi, LP Gas
J	369901	Manifold, Burner
K	369689	Plug, Pressure Test
L	369524	Main Orifice, LP
M	370186	Solenoid Valve
N	369557	Bypass Orifice, LP



# IMPINGER II ADVANTAGE DIGITAL EXPRESS BURNER ASSEMBLY

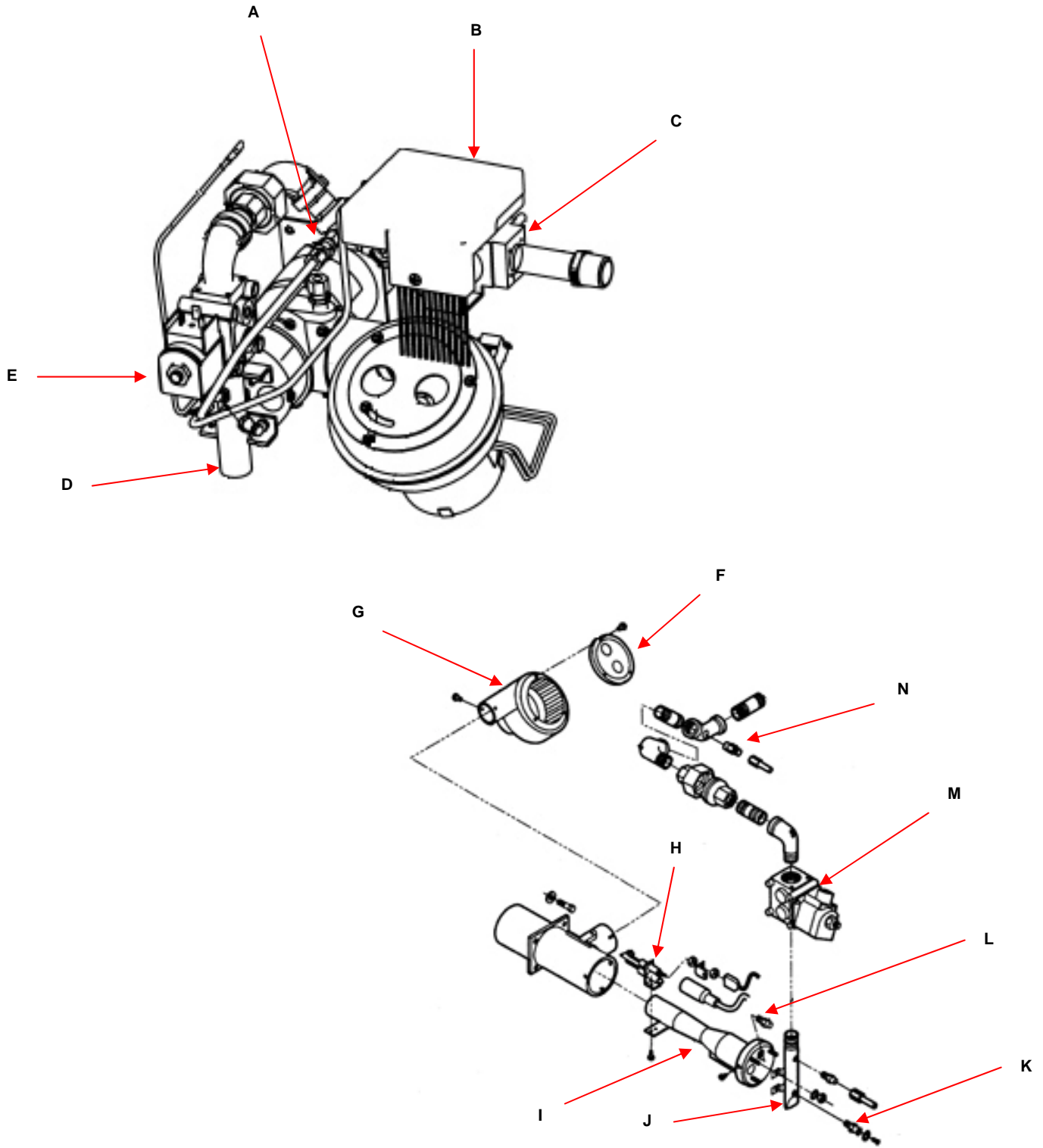

IMPINGER II ADVANTAGE DIGITAL EXPRESS  
CONVEYOR MOTOR ASSEMBLY  
ALL MODELS

LETTER	PART NUMBER	DESCRIPTION
A	370676	Conveyor Motor
B	370686	Conveyor Motor Bracket
C	370671	Coupling

IMPINGER II ADVANTAGE DIGITAL EXPRESS  
CONVEYOR MOTOR ASSEMBLY  
ALL MODELS

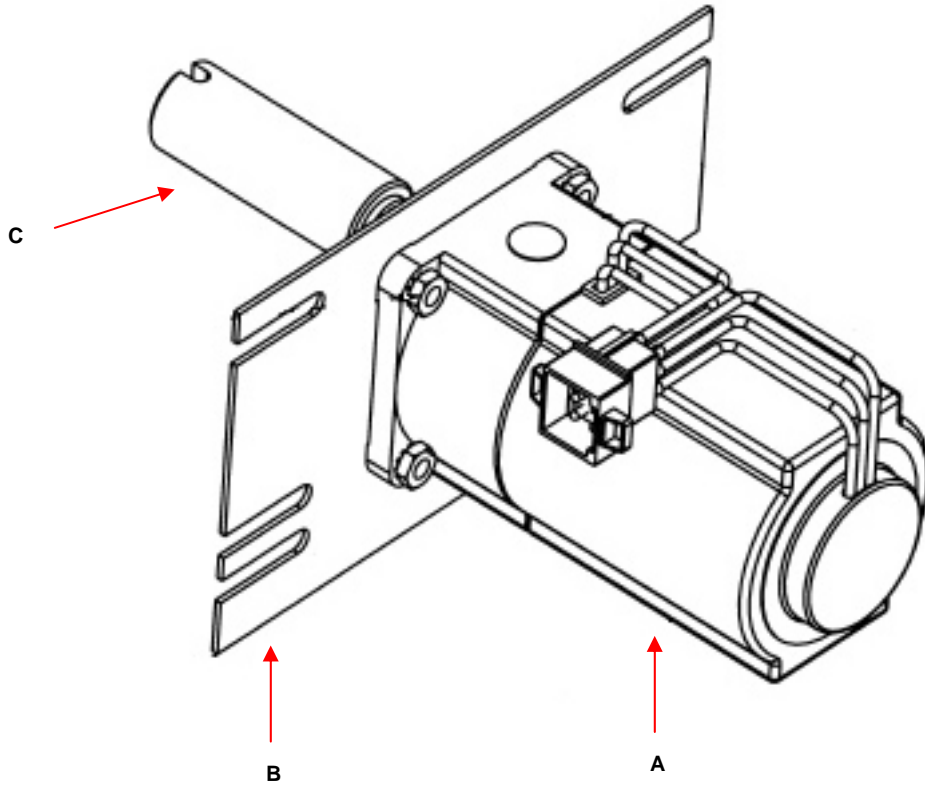

IMPINGER II ADVANTAGE DIGITAL EXPRESS  
CONTROL BOX  
1164 SERIES

LETTER	PART NUMBER	DESCRIPTION
A	370672	50 Amp Solid State Relay
B	370674	Surge Protector
C	370117	Terminal Block, 5 Pole
D	390129	J-Box Cover
E	10002030	Line Filter
F	369192	Capacitor
G	9005478	See 1164 Conveyor Motor Assembly Section
H	370417	Main Control Board
I	369507	Thermostat
J	370673	Air Switch
K	369368	Hi Limit Thermostat
L	370682	Capacitor
M	370387	EMI Filter
N	369378	Fan Motor
O	370241	Transformer
Not Shown	340034	Finger Guard
Not Shown	370364	Ground Lug
Not Shown	369432	On/Off Switch
Not Shown	370408	Control Facia
Not Shown	370417	Control Board
Not Shown	370409	Digital Display
Not Shown	370673	Air Pressure Switch

IMPINGER II ADVANTAGE DIGITAL EXPRESS  
CONTROL BOX  
1164 SERIES

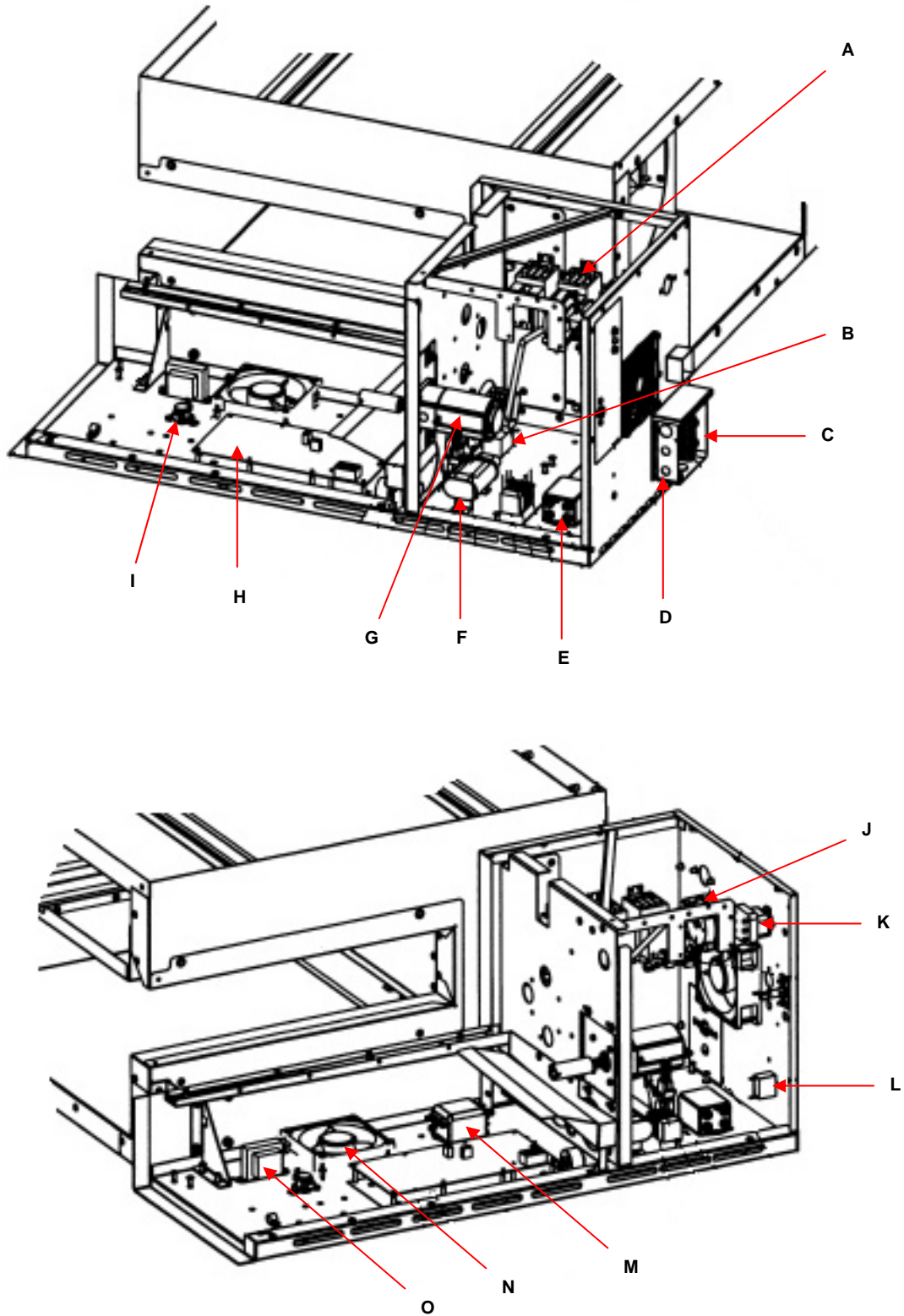

**OVEN BACK ASSEMBLY  
ALL MODELS**

<b>LETTER</b>	<b>PART NUMBER</b>	<b>DESCRIPTION</b>
A	369182	Fan
B	369899	Fan shroud
C	369655	Stand off
D	370164	Heating Element – 1164 Only
E	369549	Rear Wall - 1164
	369976	Rear Wall – 1154, 1155
	369976	Rear Wall – 1157, 1158
F	369581	Motor mount
G	369196	Motor – 1154, 1155, 1164
	369181	Motor – 1157, 1158
H	369695	Bracket, motor
I	369033	Clamp, motor
J	369681	Cover, back
K	369979	Bracket, hi-limit
L	369227	Spring
M	369541	Bracket, thermocouple

OVEN BACK ASSEMBLY  
ALL MODELS

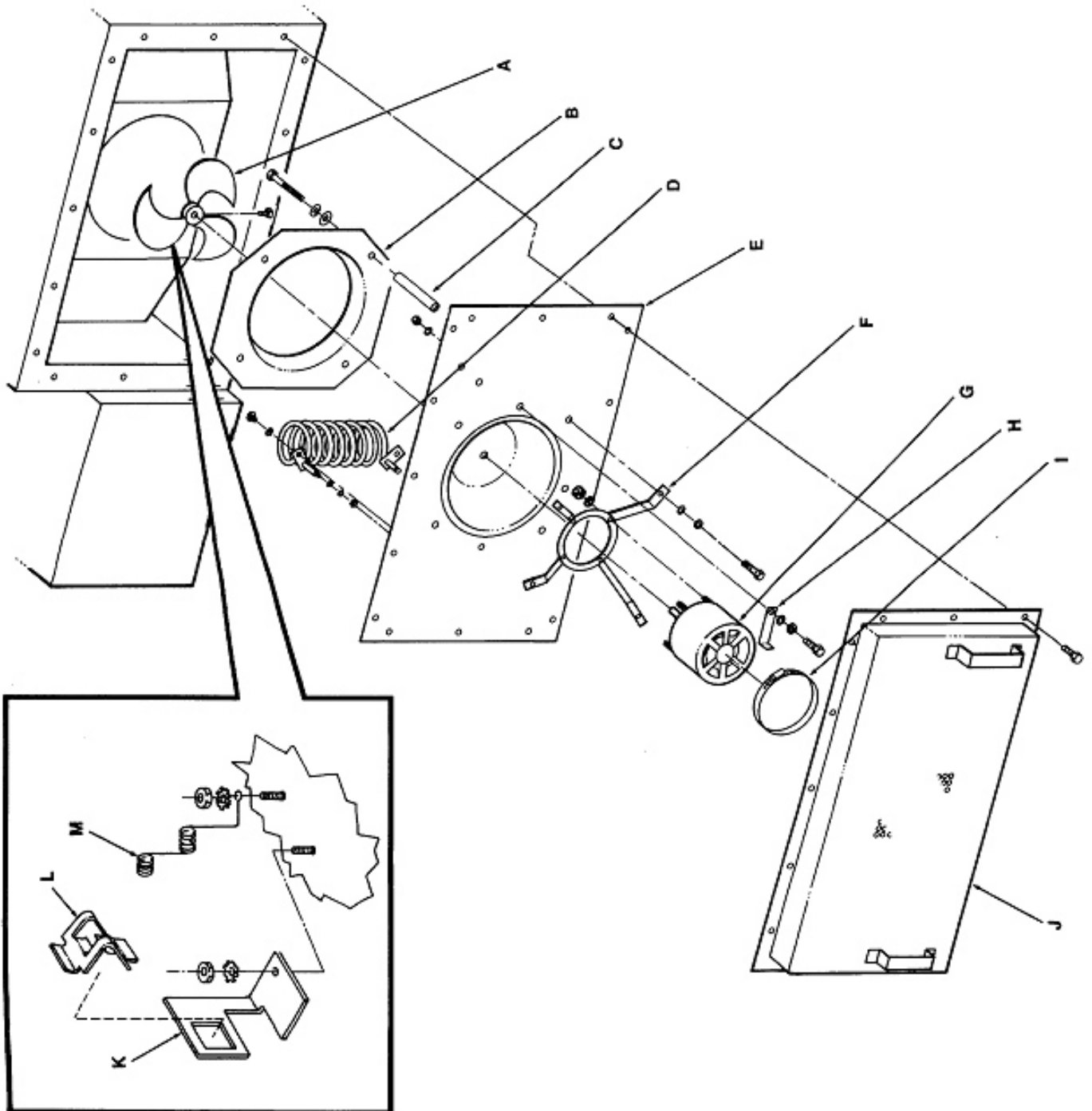

CONVEYOR / DOOR  
ALL MODELS

LETTER	PART NUMBER	DESCRIPTION
A	--	--
B	--	--
C	--	--
D	--	--
E	369223	Crumb pan, right and left
F	369223	Crumb pan, right and left
G	369666	Conveyor frame assembly
H	369226	Pan stop
J	369516	Conveyor bearing
K	369514	Idler shaft
L	369515	Sprocket (includes set screw), Regular Conveyor
	369978	Set screw
	370509	Sprocket (includes set screw), Heavy-Duty Conveyor
M	370678	Drive shaft
N	369513	Hinge
O	370413	Door assembly
P	370016	Impinger nameplate
Q	369501	Door latch & catch
R	370414	Door assembly with window
S	369927	Window frame, top
T	369925	Glass, access window
U	369926	Window frame, bottom
W	369929	Retainer, window
X	369165	Splice clip, conveyor belt
Y	369194	Conveyor belt (complete), Regular Conveyor
	369394	Conveyor belt (1-Foot section), Regular Conveyor
	370155	Conveyor Belt (complete), Heavy-Duty Conveyor
	370157	Conveyor Belt (1-Foot Section), Heavy-Duty Conveyor
Not Shown	369471	Roll Pin



CONVEYOR / DOOR

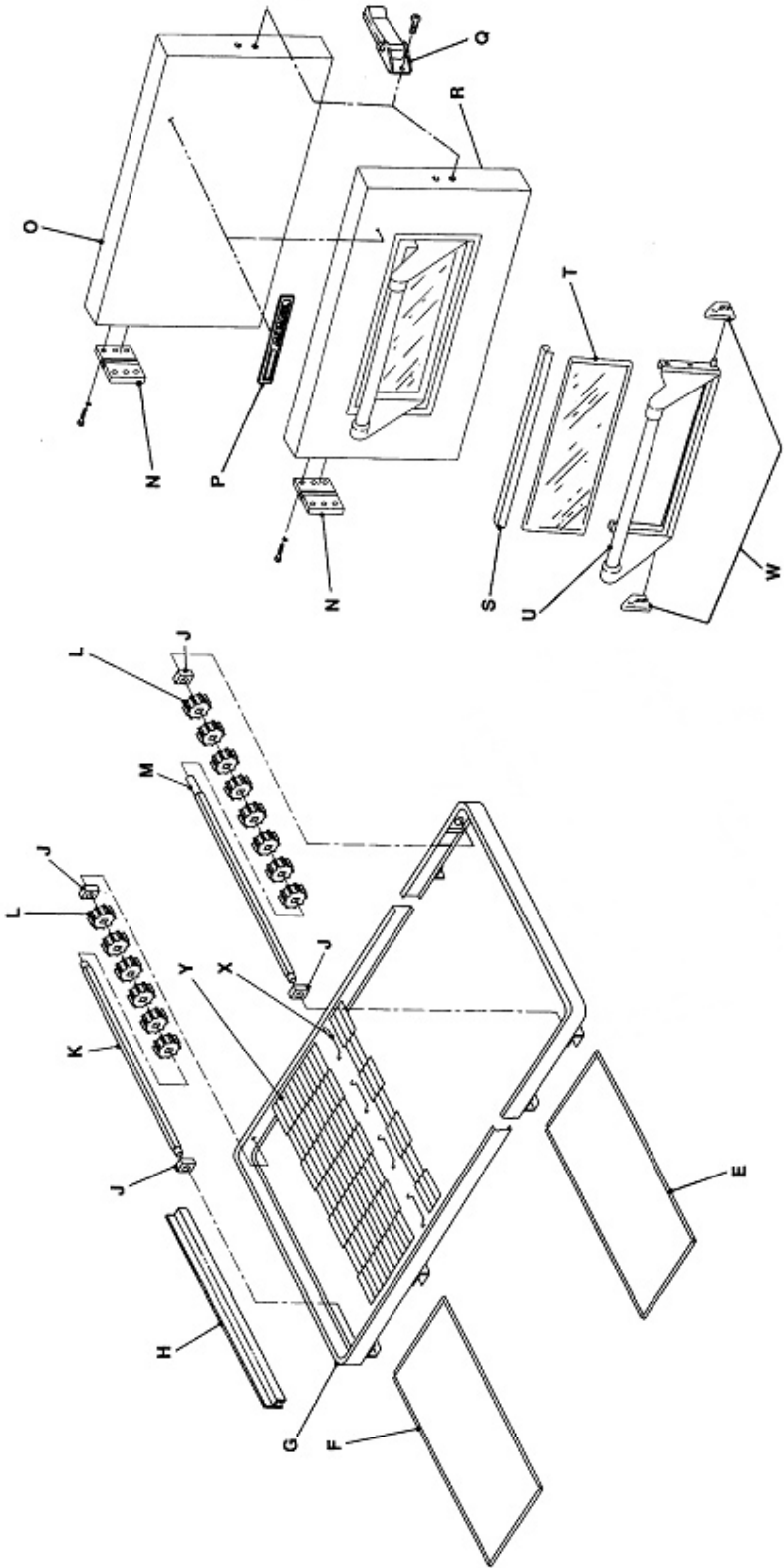

**STAINLESS STEEL ACCESS DOOR  
ALL MODELS (SN 0908210000875 AND ABOVE)**

LETTER	PART NUMBER	DESCRIPTION
	369110	Access Door Assembly
A	371140	Bracket Assembly, Left
B	371142	Dowel, Access Door
C	370722	Screw
D	371143	8-32 x 3/8 Hx Serr Flng
E	371141	Bracket Assembly, Right
F	370725	Dowel Thread
G	371144	Access Door Frame (top or bottom)
H	370723	Glass

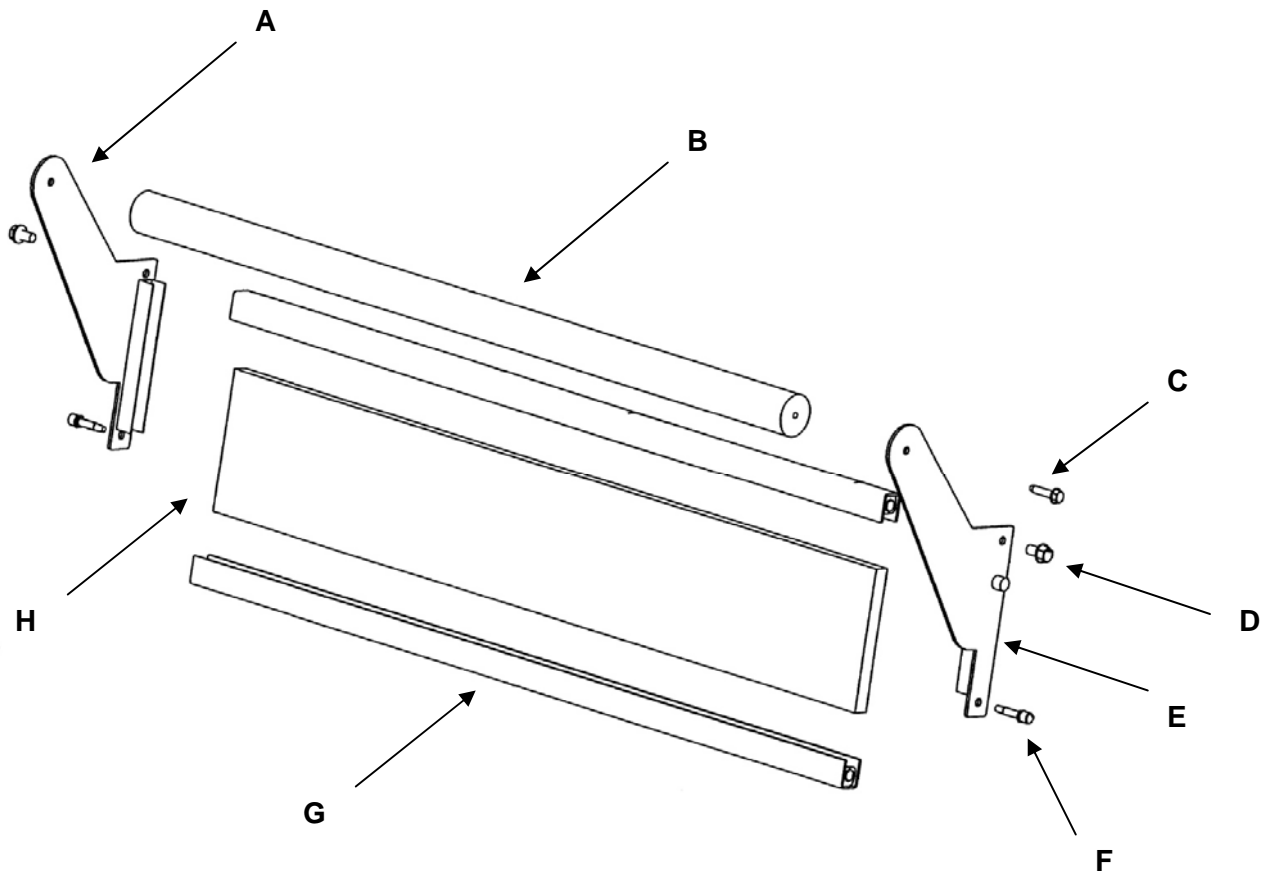

## ADDENDUM A NEW STYLE OVEN STAND (BEGINNING MARCH 16, 2009)

1. Insert the four Stand Side Bars (G) into the four holes located on each of the Front/Back Assemblies (A). Note: The Stand Side Bar that contains labels should be facing "out" so that the labels can be easily read by the operator.
2. Attach the Stand Side Bars to the Front/Back Assemblies and tighten using the 1 ¼" Hexagon Bolts (B), Washers (E) and Acorn Nuts (D) provided. Two sets each of the bolts, washers and nuts are to be used at each intersection of Stand Side Bars and Front Back Assemblies for a total of 16 sets.
3. Select Caster or Adjustable Leg and screw into nutsert in the bottom corner of each Front/Back Stand Assembly. Tighten Casters securely.
4. Set assembled Stand on casters/legs in an open, clear area and lock casters, as applicable, in preparation for mounting oven on stand.
5. When placing the oven on the stand, align the bolt holes located in the Front/Back Stand Assemblies with the holes located in the bottom of the oven. With holes in alignment, insert the 2 ½" Hexagon Bolts and tighten to secure the oven to Stand (Fig. 2).



**CAUTION:** USE EXTREME CARE IN STEP #5 TO INSURE OVEN DOESN'T SLIP OFF STAND BEFORE BOLTS HAVE SECURED OVEN TO STAND.

HARDWARE PROVIDED FOR STAND ASSEMBLY		
LETTER	PART #	DESCRIPTION
A	90000799	Front / Back Stand Assemblies
B	000151SP	Hexagon Bolt (1 ¼")
C	369231	Caster, 4"
D	2133001	Acorn Nut
E	000821SP	Washer
F	369233	Hexagon Bolt (2 ½" )
G	10004656	Stand Side Bar
H		Adjustable Leg for 1127-1 stand
Not Shown	9002533	Shelf for 1127-1 stand
Not Shown		Hexagon Bolt (1/2") for double-stack oven configuration

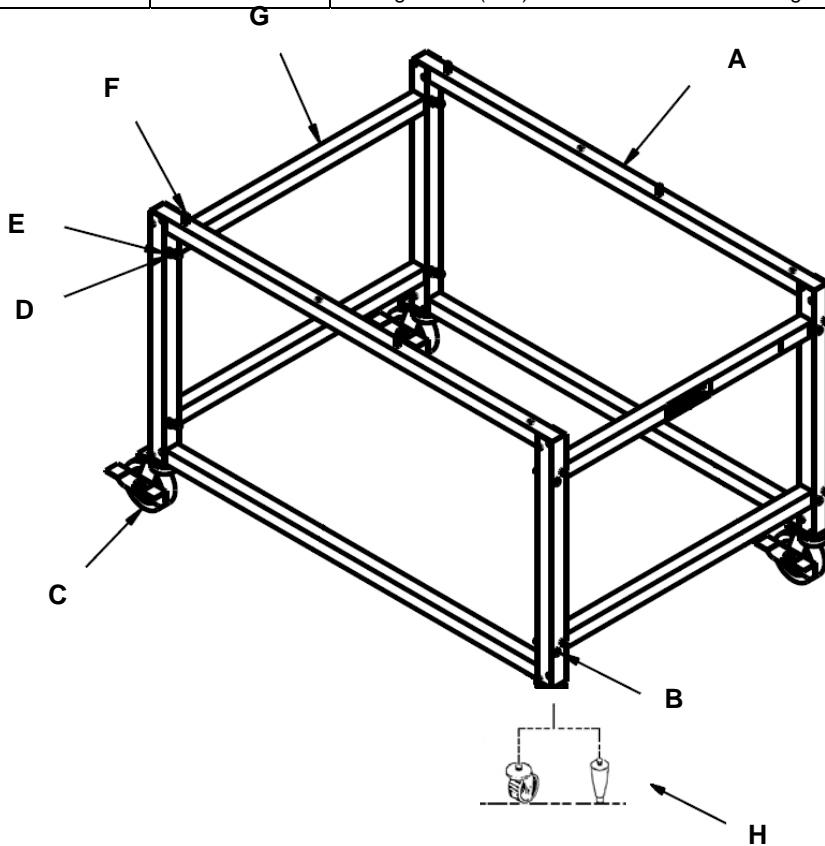



---

Lincoln Foodservice Products, LLC  
1111 North Hadley Road  
Fort Wayne, Indiana 46804  
Telephone: 260.459.8200  
Fax: 260.436.0735  
Technical Support: 260.459.8200  
[lincolnfp.com](http://lincolnfp.com)